

CAREL

μRack

Controller for condensing units
and compact compressor racks



USER MANUAL

→ **LEGGI E CONSERVA
QUESTE ISTRUZIONI** ←
**READ AND SAVE
THESE INSTRUCTIONS**

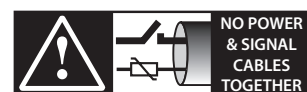

READ CAREFULLY IN THE TEXT!

μRack

+0300026EN - ENG

Up to date version available on

www.carel.com

GENERAL WARNINGS



CAREL bases the development of its products on decades of experience in refrigeration, on continuous investments in technological innovations to products, procedures and strict quality processes with in-circuit and functional testing on 100% of its products, and on the most innovative production technology available on the market. CAREL and its subsidiaries/affiliates nonetheless cannot guarantee that all the aspects of the product and the software included with the product respond to the requirements of the final application, despite the product being developed according to start-of-the-art techniques. The customer (manufacturer, developer or installer of the final equipment) accepts all liability and risk relating to the configuration of the product in order to reach the expected results in relation to the specific final installation and/or equipment. CAREL may, based on specific agreements, act as a consultant for the successful commissioning of the final unit/application, however in no case does it accept liability for the correct operation of the final equipment/system. The CAREL product is a state-of-the-art product, whose operation is specified in the technical documentation supplied with the product or can be downloaded, even prior to purchase, from the website www.carel.com. Each CAREL product, in relation to its advanced level of technology, requires setup/configuration/programming/commissioning to be able to operate in the best possible way for the specific application. Failure to complete such operations, which are required/indicated in the user manual, may cause the final product to malfunction; CAREL accepts no liability in such cases. Only qualified personnel may install or carry out technical service on the product. The customer must only use the product in the manner described in the documentation relating to the product. In addition to observing any further warnings described in this manual, the following warnings must be heeded for all CAREL products:

- prevent the electronic circuits from getting wet. Rain, humidity and all types of liquids or condensate contain corrosive minerals that may damage the electronic circuits. In any case, the product should be used or stored in environments that comply with the temperature and humidity limits specified in the manual;
- do not install the device in particularly hot environments. Too high temperatures may reduce the life of electronic devices, damage them and deform or melt the plastic parts. In any case, the product should be used or stored in environments that comply with the temperature and humidity limits specified in the manual;
- do not attempt to open the device in any way other than described in the manual.
- do not drop, hit or shake the device, as the internal circuits and mechanisms may be irreparably damaged;
- do not use corrosive chemicals, solvents or aggressive detergents to clean the device;
- do not use the product for applications other than those specified in the technical manual.

All of the above suggestions likewise apply to the controllers, serial cards, programming keys or any other accessory in the CAREL product portfolio. CAREL adopts a policy of continual development. Consequently, CAREL reserves the right to make changes and improvements to any product described in this document without prior warning. The technical specifications shown in the manual may be changed without prior warning. The liability of CAREL in relation to its products is specified in the CAREL general contract conditions, available on the website www.carel.com and/or by specific agreements with customers; specifically, to the extent where allowed by applicable legislation, in no case will CAREL, its employees or subsidiaries/affiliates be liable for any lost earnings or sales, losses of data and information, costs of replacement goods or services, damage to things or people, downtime or any direct, indirect, incidental, actual, punitive, exemplary, special or consequential damage of any kind whatsoever, whether contractual, extra-contractual or due to negligence, or any other liabilities deriving from the installation, use or impossibility to use the product, even if CAREL or its subsidiaries/affiliates are warned of the possibility of such damage.

DISPOSAL

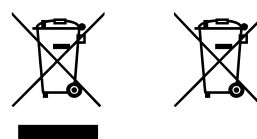

Fig. 1

Fig. 2

INFORMATION FOR USERS ON THE CORRECT HANDLING OF WASTE ELECTRICAL AND ELECTRONIC EQUIPMENT (WEEE)

The product is made up of metal parts and plastic parts. In reference to European Union directive 2002/96/EC issued on 27 January 2003 and related national legislation, please note that:

- WEEE cannot be disposed of as municipal waste and such waste must be collected and disposed of separately;
- the public or private waste collection systems defined by local legislation must be used. In addition, the equipment can be returned to the distributor at the end of its working life when buying new equipment;
- the equipment may contain hazardous substances: the improper use or incorrect disposal of such may have negative effects on human health and on the environment;
- the symbol (crossed-out wheeled bin) shown on the product or on the packaging and on the technical leaflet indicates that the equipment has been introduced onto the market after 13 August 2005 and that it must be disposed of separately;
- in the event of illegal disposal of electrical and electronic waste, the penalties are specified by local waste disposal legislation.

Warranty on materials: 2 years (from production date, excluding consumables).

Approval: the quality and safety of CAREL S.p.A. products are guaranteed by the ISO 9001 certified design and production system.

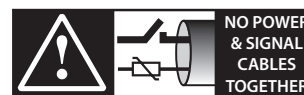

Separate as much as possible the probe and digital input cables from cables to inductive loads and power cables, so as to avoid possible electromagnetic disturbance. Never run power cables (including the electrical panel cables) and signal cables in the same conduits.

Key to the symbols:



Caution: to bring critical issues to the attention of those using the product.



Notice: to focus attention on important topics; in particular the practical application of the various product functions.



Caution: this product is to be integrated and/or incorporated into the final apparatus or equipment. Verification of conformity to the laws and technical standards in force in the country where the final apparatus or equipment will be operated is the manufacturer's responsibility. Before delivering the product, Carel has already completed the checks and tests required by the relevant European directives and harmonised standards, using a typical test setup, which however cannot be considered as representing all possible conditions of the final installation.

Index

1. Introduction	7
1.1 Main functions	7
1.2 Models	7
1.3 Accessories	7
2. Installation	10
2.1 Warnings	10
2.2 Panel version	10
2.3 DIN rail version	11
2.4 Electrical installation	12
2.5 Probe/digital input connection	14
2.6 Positioning inside the panel	14
2.7 Electrical installation	14
2.8 Serial port connections	15
2.9 Positioning of probes/components	15
2.10 Input/output configuration	16
3. Commissioning	19
3.1 Commissioning via smartphone	19
3.2 Via PC (serial/USB): with configuration tool	22
3.3 Via user terminal	24
3.4 Unit set-up parameter list	25
4. User interface	26
4.1 Introduction	26
4.2 User terminal	26
4.3 Standard display	27
5. Functions	30
5.1 Unit ON/OFF	30
5.2 Control	30
5.3 Compressors	33
5.4 Fans	39
5.5 Energy saving	42
5.6 Manual device management	44
5.7 Settings	45
5.8 Default value management	45
5.9 Generic functions	45
6. Parameter table	49
6.1 Unit	49
6.2 Compressors	49
6.3 Fans	53
6.4 Input/Output	54
6.5 Alarms	56
6.6 Generic functions	57
6.7 Time bands	59
6.8 BMS port	59
7. Alarms and signals	60
7.1 Types of alarms	60
7.2 Alarm signals	60
7.3 Description of the main alarms	61
7.4 Alarm list	64
8. Technical specifications	68
8.1 Connector/cable table	70
9. Release notes	70

1. INTRODUCTION

µRack is the Carel solution for the complete management of small compressor rack units with up to 2 suction lines, for synchronous control of medium and low temperatures. The maximum configuration manages up to 2 suction lines and 6 compressors in total (4+2)⁽¹⁾. The distinctive feature of µRack is complete control of high efficiency units through the management of modulating devices, combined with control logic to optimise overall system efficiency, including the special Floating Condenser and Floating Suction functions. The user terminal, which allows wireless connectivity with mobile devices, can be purchased separately on some models, while on others it is built-in. CAREL's "APPLICA" app, available on Google Play for the Android operating system and Apple store for iOS, makes it easier to configure parameters and commission the unit in the field.

1.1 Main functions

Ref.	Description
Main features	Up to two suction lines and six compressors in total (4 MT + 2 LT) Management of a common condensing stage with up to 4 ON/OFF or inverter-driven fans
Hardware	BASIC model for panel mounting: management of ON-OFF and 0-10 V inverter compressors MEDIUM model for DIN rail mounting: management of ON-OFF compressors, 0-10 V inverter compressors and Digital Scroll™ compressors with external SSR connected to a 0-10 V output ADVANCED model for DIN rail mounting: management of ON-OFF, inverter and Digital Scroll™ compressors via built-in SSR
User interface	7-segment, 2-row LED display, communication via APPLICA app (compatible with NFC and Bluetooth LE) for mobile devices
Temperature control	2 suction lines - dead band 2 suction lines - PID Condensing stage - dead band Condensing stage - PID
Compressor rotation	FIFO, LIFO or timed
Compressor management	Hermetic/semi-hermetic compressors, with capacity control (maximum 2 steps) Generic scroll compressors Compressors with external inverter via 0-10 V signal Digital Scroll™ compressors via built-in or external SSR (0-10 V output signal from controller)
Oil management	Oil recovery function (extended operation at part load)
Prevent	Prevention of compressor operating limits in relation to suction and condensing pressure High discharge temperature prevention Low superheat prevention with modulating compressor protection
Alarms (see "Alarms")	Management of automatic and manual reset according to alarm severity Alarm log (up to 20 events): alarm and reset date and time recorded
Connectivity/supervision	2 RS485 serial ports, Fieldbus and BMS
Modbus® RTU	Baud rate up to 115200 bit/s Frame configurable by parity (none, even, odd) and stop bits (1 or 2); databits fixed at 8 bits.

Tab. 1.a

1.2 Models

P/N	Mounting	Connectivity	Compressor management:	Notes
U20R00MRK0280	panel	NFC	On-Off and Inverter **	BASIC version, built-in display
U20R00MRK0380	panel	NFC + BLE	On-Off and Inverter **	BASIC version, built-in display
U20R00MRK0290	DIN rail	NFC	On-Off and Inverter **	MEDIUM version, built-in display
U20R00MRK0390	DIN rail	NFC + BLE	On-Off and Inverter **	MEDIUM version, built-in display
U20R00MRK0300 *	DIN rail	-	On-Off, Inverter and Digital Scroll™	ADVANCED version, no display, built-in SSR

Tab. 1.b

* To be combined with the display (Table 1.c)

** Digital Scroll™ compressors only with external SSR relays connected to 0-10V outputs

1.3 Accessories

1.3.1 µRack user terminal

The user terminal, built-in on the panel models or available separately, includes the display and keypad, comprising four buttons that, when pressed alone or combined with other buttons, access the operations available for the "User" and "Service" profiles (see the paragraph on "Commissioning"). Connectivity - NFC or NFC + Bluetooth (BLE) based on the model - allows interaction with mobile devices and simplifies unit commissioning (after having installed the CAREL "Applica" app, available on Google Play for the Android operating system and Apple store for iOS, see chapters "Commissioning" and "User interface"). For assembly, see the technical leaflet +0500146IE.

¹ The only limitation to configuration depends solely on the availability of I/Os on the controller.



P/N	Description
AX2000PD20030	Display (NFC+ BLE)
ACS00CB000020	Connection cable L=1.5 m
ACS00CB000010	Connection cable L=3 m

Fig. 1.a

Tab. 1.c

1.3.2 Connector kit and wired connectors



P/N	Description
UCHCONP010	Cable and connector kit for μ Chiller / μ Rack panel MOLEX/FREE 100 cm
UCHCOND010	Cable and connector kit for μ Chiller / μ Rack DIN MOLEX/FREE 100 cm
UCHCONP000	Connector kit for μ Chiller / μ Rack panel MOLEX/FREE
UCHCOND000	Connector kit for μ Chiller / μ Rack DIN MOLEX/FREE

Fig. 1.b

Tab. 1.d

1.3.3 Temperature sensors

NTC sensors for measuring the temperatures in the user circuit, the outdoor air or source, and the refrigeration circuit. NTC**HT sensors are recommended for discharge temperature measurement.



Fig. 1.c

P/N	Type	Range
NTC060HF01	10 k Ω \pm 1% @25°C, IP67	-50 to 90°C strap-on
NTC060HP00	10 k Ω \pm 1% @25°C, IP67	-50 to 50 °C (105°C in air)
NTC060HT00	50 k Ω \pm 1% @25°C, IP67	-30 to 100°C 95% rH in air (150°C in a dry environment)

Tab. 1.e

Notice: see manuals +040010025 (ITA- ENG) /+040010026 (FRE-GER) for guidelines on installing the sensors on the unit.

1.3.4 Pressure sensors

Active probes for measuring:

1. evaporation pressure in the circuit, used to control superheat and the operating limits;
2. condensing pressure in the circuit, to control the condensing stage and manage the operating limits.

See technical leaflet +050000488.



Fig. 1.d

P/N	Type	Application	Range
SPKT0*13P*	0 to 5 V	LP R407C, R290	-1 to 9.3 barg
SPKT0*43P*	0 to 5 V	LP R410A, R32	0 to 17.3 barg
SPKT0*33P*	0 to 5 V	HP R407C, R290	0 to 34.5 barg
SPKT0*B6P*	0 to 5 V	HP R410A, R32	0 to 45 barg
SPKT0011C*	4 to 20 mA	LP R407C, R290	0 to 10 barg
SPKT0041C*	4 to 20 mA	LP R410A, R32	0 to 18.2 barg
SPKT0031C*	4 to 20 mA	HP R407C, R290	0 to 30 barg
SPKT00B1C*	4 to 20 mA	HP R410A, R32	0 to 44.8 barg
SPKC00*310	IP67 connection cable		L= 2 to 12 m
SPKC00*311	IP67 connection cable - 50 pcs		L= 0.65 to 1.3 m

Tab. 1.f

1.3.5 Local supervision by boss micro



Fig. 1.e

boss micro is CAREL's new family of IoT supervisors to enable monitoring and local or remote supervisory services for HVAC/R systems with up to 15 units. Compact, standard installation inside an electrical panel and a local LED interface with immediate indication of communication status make boss micro easy to install in the field, without the need for experts in connectivity products.

1.3.6 USB/RS485 converter (CVSTDUMOR0)



Fig. 1.f

Electronic device used to interface an RS485 network to a personal computer via the USB port. See technical leaflet +050000590.

2. INSTALLATION

2.1 Warnings

⚠ Caution: avoid installing the controller in environments with the following characteristics:

- temperature and humidity that do not comply with the ambient operating conditions (see "Technical specifications");
- strong vibrations or knocks;
- exposure to water sprays or condensate;
- exposure to aggressive and polluting atmospheres (e.g.: sulphur and ammonia gases, saline mist, smoke) which may cause corrosion and/or oxidation;
- strong magnetic and/or radio frequency interference (thus avoid installation near transmitting antennae);
- exposure to direct sunlight and the elements in general;
- wide and rapid fluctuations in ambient temperature;
- exposure to direct sunlight, the weather in general and dust (formation of corrosive patina with possible oxidation and reduction of insulation).

2.2 Panel version

2.2.1 Dimensions - mm (in)

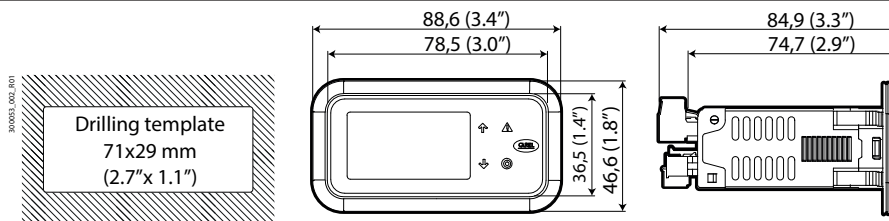

Fig. 2.a

2.2.2 Mounting

⚠ Caution: before carrying out any maintenance, disconnect the controller from the power supply by moving the main system switch to "off".

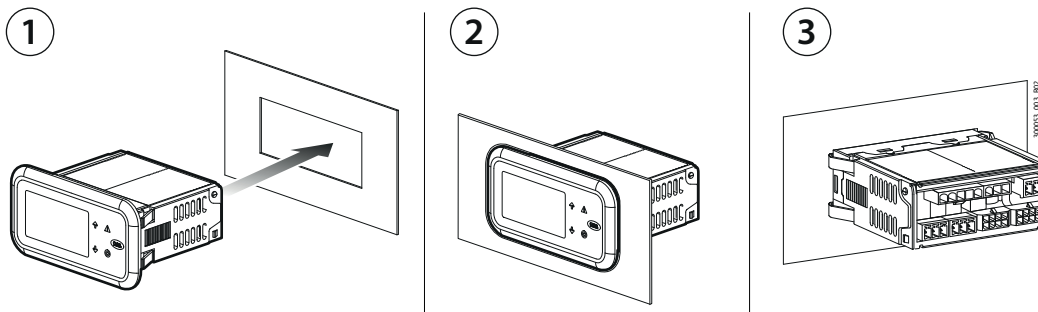

Fig. 2.b

1. Place the controller in the opening, pressing lightly on the side anchoring tabs.
2. Then press on the front until fully inserted (the side tabs will bend, and the catches will attach the controller to the panel).

⚠ Caution: IP65 front protection is guaranteed only if the following conditions are met:

- maximum deviation of the rectangular opening from flat surface: ≤ 0.5 mm;
- thickness of the electrical panel sheet metal: 0.8-2 mm;
- maximum roughness of the surface where the gasket is applied: ≤ 120 μ m.

📌 Notice: the thickness of the sheet metal (or material) used to make the electrical panel must be adequate to ensure safe and stable mounting of the product.

2.2.3 Removal

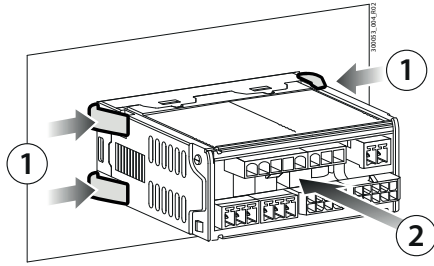

Fig. 2.c

1. Open the electrical panel from the rear and press the anchoring tabs and then the controller to remove it.
2. Exert slight pressure on the controller until it is removed.

⚠ Caution: the operation does not require the use of a screwdriver or other tools.

2.3 DIN rail version

2.3.1 Dimensions - mm (in)

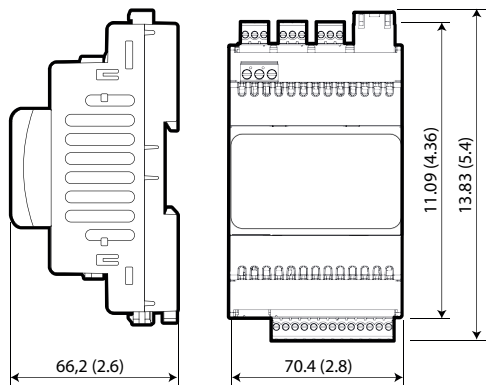
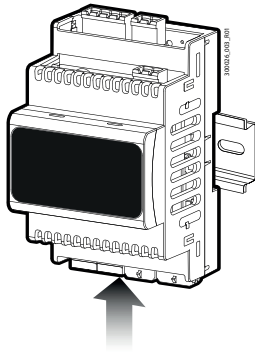

Fig. 2.d

2.3.2 Mounting



Apply slight pressure to the controller resting on the DIN rail until the rear tab clicks into place.

Fig. 2.e

2.3.3 Removal

Use a screwdriver as a lever in the hole to lift and release the tab. The tab is held in the locked position by return springs.

2.3.4 User terminal connection

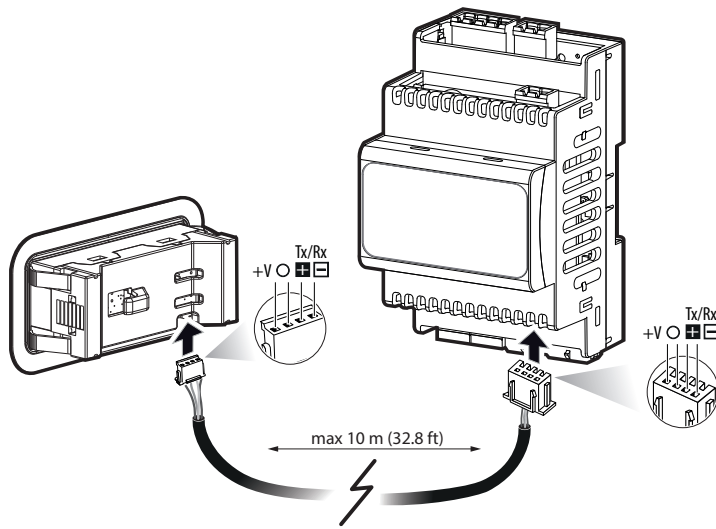

The figure shows the connection of the external display for the ADVANCED version. It is recommended to use the special connection cables shown in paragraph 1.3.

Fig. 2.f

2.4 Electrical installation

⚠ Caution: before carrying out any maintenance, disconnect the controller from the power supply by moving the main system switch to "off".

2.4.1 Description of the terminals

Panel model

Basic

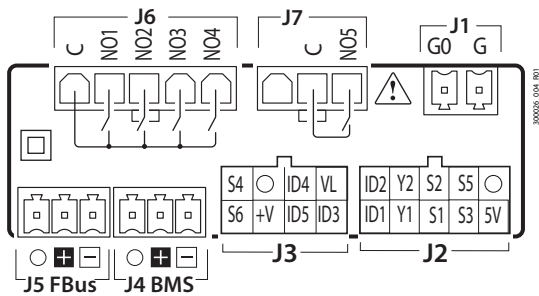

Fig. 2.g

DIN rail model
Medium

Fig. 2.h

Advanced

Fig. 2.i

Ref.	Description
J1	G0 Power supply G Power supply: reference
J2	5V Ratiometric probe power supply S3 Analogue input 3 S1 Analogue input 1 Y1 Analogue output 1 ID1 Digital input 1 O GND: reference for probes, digital inputs and analogue outputs S5 Analogue input 5 S2 Analogue input 2 Y2 Analogue output 2 ID2 Digital input 2
J3	ID3 Digital input 3 ID5 Digital input 5 +V Power supply to 4-20 mA active probes S6 Analogue input 6 VL Not used ID4 Digital input 4 O GND: reference for analogue and digital inputs S4 Analogue input 4
J4	- BMS serial port (RS485): Rx-/Tx- + BMS serial port (RS485): Rx+/Tx+ O BMS serial port (RS485): GND

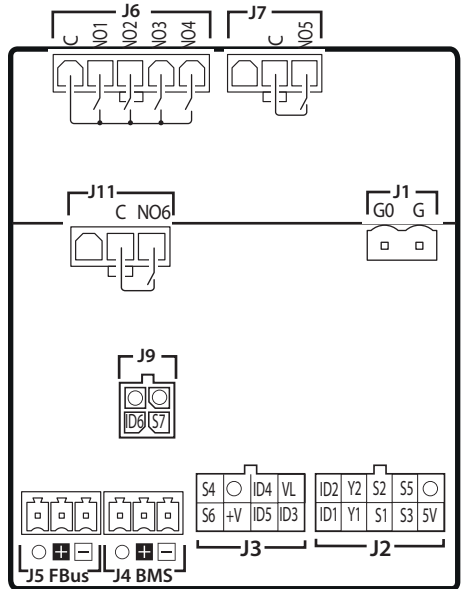
Ref.	Description
J5	- Fieldbus serial port (RS485): Rx-/Tx- + Fieldbus serial port (RS485): Rx+/Tx+ O Fieldbus serial port (RS485): GND
J6	C Common for relays 1, 2, 3, 4 NO1 Digital output (relay) 1 NO2 Digital output (relay) 2 NO3 Digital output (relay) 3 NO4 Digital output (relay) 4
J7	C Common for relay 5 NO5 Digital output (relay) 5
J8	- Unit terminal connector (AX2000PD20030)
J9	S7 Analogue input 7 ID6 Digital input 6 O GND: reference for analogue and digital inputs O GND: reference for analogue and digital inputs
J10*	G Power supply for Ultracap module G0 Power supply reference for Ultracap module Vbat Emergency power supply from Ultracap module
J11*	- C Common for relay/SSR 6 NO6 Digital output (relay/SSR) 6
J14*	- Carel ExV unipolar valve connector (**)

Tab. 2.a

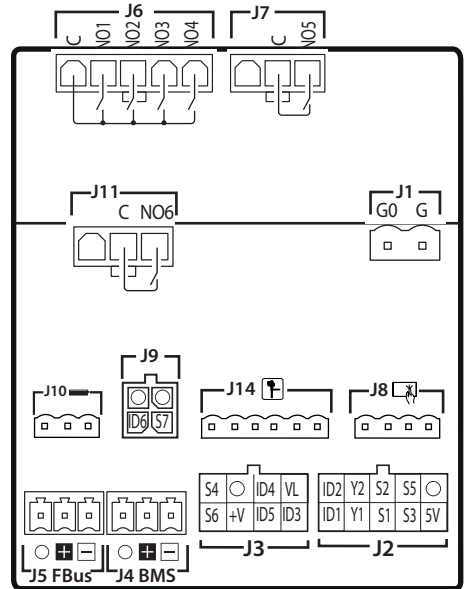
(*) DIN Advanced models only

(**) currently not used by specific functions

2.5 Probe/digital input connection

Passive temperature probes

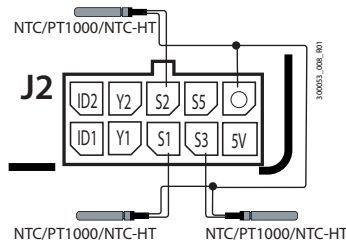

Fig. 2.j

0-5 V ratiometric pressure probes

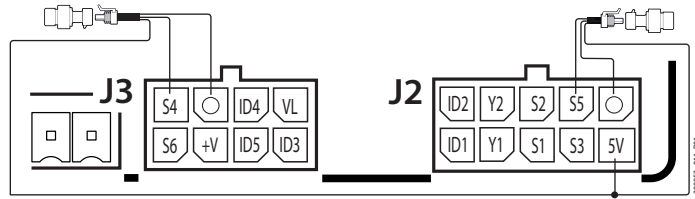

Fig. 2.k

0-10 Vdc probes

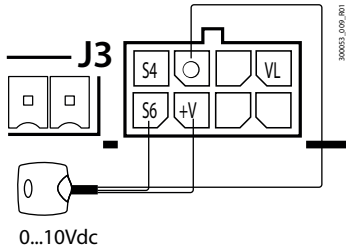

Fig. 2.l

ⓘ Notice: 0= GND

4-20 mA probes

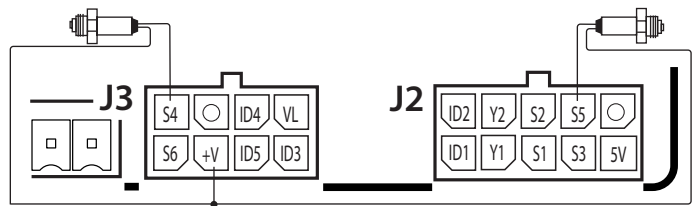

Fig. 2.m

2.6 Positioning inside the panel

The position of the controller in the electrical cabinet must be chosen so as to guarantee correct physical separation from the power components (solenoids, contactors, actuators, inverters, ...) and the connected cables. Proximity to such devices/cables may create random malfunctions that are not immediately evident. The structure of the panel must allow the correct flow of cooling air.

2.7 Electrical installation

⚠ Caution: When laying the wiring, “physically” separate the power part from the control part. The proximity of these two sets of wires will, in most cases, cause problems of induced disturbance or, over time, malfunctions or damage to the components. The ideal solution is to house these two circuits in two separate cabinets. Sometimes this is not possible, and therefore the power part and the control part must be installed in two separate areas inside the same panel.

For the control signals, it is recommended to use shielded cables with twisted wires. If the controller cables have to cross over the power cables, the intersections must be as near as possible to 90 degrees, always avoiding running the controller cables parallel to the power cables.

Pay attention to the following warnings:

- use cable ends suitable for the corresponding terminals. Loosen each screw and insert the cable ends, then tighten the screws. When the operation is completed, slightly tug the cables to check they are sufficiently tight;
- separate as much as possible the probe signal, digital input and serial line cables from the cables carrying inductive loads and power cables to avoid possible electromagnetic disturbance. Never run power cables (including the electrical cables) and probe signal cables in the same conduits. Do not install the probe cables in the immediate vicinity of power devices (contactors, circuit breakers or similar);
- reduce the path of the probe cables as much as possible, and avoid spiral paths that enclose power devices;
- avoid touching or nearly touching the electronic components fitted on the boards to avoid electrostatic discharges (extremely damaging) from the operator to the components;
- do not secure the cables to the terminals by pressing the screwdriver with excessive force, to avoid damaging the controller: maximum tightening torque: 0.22-0.25 N·m.
- For applications subject to considerable vibrations (1.5 mm pk-pk 10/55 Hz), secure the cables connected to the controller around 3 cm from the connectors using cable ties;
- all the extra low voltage connections (analogue and digital inputs, analogue outputs, serial bus connections, power supplies) must have reinforced or double insulation from the mains network.

2.8 Serial port connections

For serial connections (FBus and BMS ports), the cables used must be suitable for the RS485 standard (shielded twisted pair, see the specifications in the following table).

Device	Serial port	Lmax (m)	Wire/wire capacitance (pF/m)	Resistance on first and last device	Max no. devices on bus	Data rate (bit/s) **
µRack	FBus	10	<90	-	16	19200
Supervisor/PC	BMS	500	<90	120 Ω	246 (*)	19200

(*) The maximum number of devices depends on the Client device used in the network and the use of signal amplifiers.

(**) Can be modified by parameter

⚠ Caution: connect the shield to the controller GND, do not connect GND to earth. Connect a 120 Ω terminating resistor between the Tx/Rx+ and Tx/Rx- terminals on the last controller on the RS485 line.

2.8.1 Serial port configuration

The BMS port communication parameters can be set using parameters H0, H1 and H2. By default, µRack leaves the factory with serial address 1, baud rate 19200 bit/s, 1 stop bit and no parity.

User	Code	Description	Def.	Min.	Max.	UOM
S	H0	BMS serial address	1	1	247	-
S	H1	BMS parity and stop bits: BMS serial port configuration (stop bits and parity) 0= 1 stop bit 1, no parity; 1= 2 stop bits, no parity; 2= 1 stop bit, even parity; 3= 2 stop bits, even parity; 4= 1 stop bit, odd parity; 5= 2 stop bits, odd parity	0	0	5	-
S	H2	BMS port speed (baud rate): 0= 1200 3= 9600 6= 57600 1= 2400 4= 19200 7= 115200 2= 4800 5= 38400	4	0	8	bit/s

Tab. 2.b

2.9 Positioning of probes/components

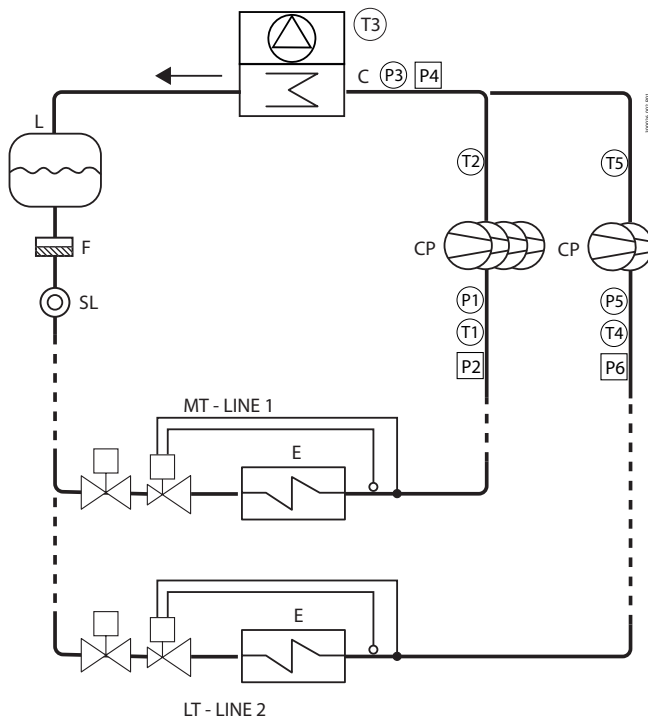

Fig. 2.n

Ref	Description
CP	Compressors
C	Condenser
E	Evaporators
F	Filter-drier
L	Liquid receiver
SL	Liquid sight glass
P1	Line 1 suction pressure
T1	Line 1 suction temperature
P2	Line 1 low pressure switch
T2	Line 1 discharge temperature
P3	Condensing pressure
T3	Outside temperature
P4	High pressure switch
T4	Line 2 suction temperature
P5	Line 2 suction pressure
T5	Line 2 discharge temperature
P6	Line 2 low pressure switch

Tab. 2.c

2.10 Input/output configuration

Information on how to configure the μ Rack inputs and outputs is shown below.

Basic model

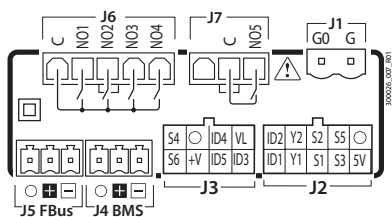

Fig. 2.o

Medium model

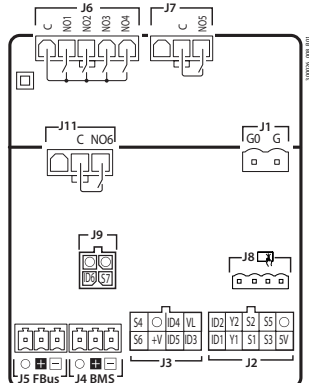

Fig. 2.p

Advanced model

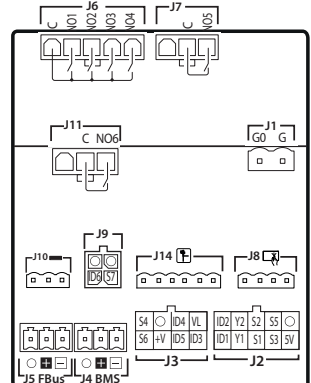

Fig. 2.q

2.10.1 Analogue inputs

The μ Rack analogue inputs are divided into 4 groups, according to the type of probe connected; each group can be configured using specific parameters, all of the probes in each group must be the same type, mixed configurations are not allowed in the same group. The groups and the list of parameters used to configure the different analogue inputs are shown below:

Group	Sensor	Configuration parameter	Compatibility	Default
GRP1	S1 S2 S3	/P1	0= PT1000; 1= NTC	NTC
GRP2	S4 S5	/P2	0= PT1000; 1= NTC; 2= 0-5 V; 3= 4-20 mA	0 to 5 V
GRP3	S6	/P3	0= PT1000; 1= NTC; 2= 0-5 V; 3= 4-20 mA; 4= 0-10 V; 5= NTC HT; 6= 0.5-4.5 V	NTC HT
GRP4*	S7*	/P4	1= NTC	NTC

Tab. 2.d

(*) available only on DIN version

Using the appropriate channel configuration parameters for the analogue inputs, the position of the signal to be read can be configured freely, choosing between the available inputs, with the only limit being the type of probe. The value 0 is used to disable the specific input:

User	Code	Description	Def.	Min.	Max.	UOM
S	/FT	Assign line 1 suction pressure probe channel – see /F3	4	0	7	-
S	/FD	Assign line 1 suction temperature probe channel – see /F3	3	0	7	-
S	/Fo	Assign line 1 discharge temperature probe channel – see /F3	6	0	7	-
S	/FTB	Assign line 2 suction pressure probe channel – see /F3	0	0	7	-
S	/FDB	Assign line 2 suction temperature probe channel – see /F3	0	0	7	-
S	/Fob	Assign line 2 discharge temperature probe channel – see /F3	0	0	7	-
S	/FS	Assign condensing pressure probe channel – see /F3	5	0	7	-
S	/F3	Assign outside temperature probe channel (0= function disabled; 1= S1; 2= S2; ...; 7= S7)	0	0	7	-
S	/Fi	Assign room temperature probe channel – see /F3	0	0	7	-
S	/FG	Assign generic probe channel – see /F3	0	0	7	-
M	/2	Analogue probe measurement stability (filter) 1 = probe reading not delayed ... 15 = maximum probe reading delay	9	1	15	-
S	/CT	Suction pressure probe calibration, line 1	0.0	-99.9/ -1448.9 (*)	99.9/ 1448.9 (*)	Δ barg/ Δ psig
S	/CD	Suction temperature probe calibration, line 1	0.0	-99.9/ -179.8	99.9/ 179.8	Δ °C/ Δ °F
S	/Co	Discharge temperature probe calibration, line 1	0.0	-99.9/ -179.8	99.9/ 179.8	Δ °C/ Δ °F
S	/CTB	Suction pressure probe calibration, line 2	0.0	-99.9/ -1448.9 (*)	99.9/ 1448.9 (*)	Δ barg/ Δ psig
S	/CDB	Suction temperature probe calibration, line 2	0.0	-99.9/ -179.8	99.9/ 179.8	Δ °C/ Δ °F
S	/Cob	Discharge temperature probe calibration, line 1	0.0	-99.9/ -179.8	99.9/ 179.8	Δ °C/ Δ °F
S	/CS	Condensing temperature probe calibration	0.0	-99.9-1448.9 (*)	99.9/ 1448.9 (*)	Δ barg/ Δ psig
S	/C3	Outside temperature probe calibration	0.0	-99.9/ -179.8	99.9/ 179.8	Δ °C/ Δ °F
S	/Ci	Room temperature probe calibration	0.0	-99.9/ -179.8	99.9/ 179.8	Δ °C/ Δ °F
S	/CG	Generic probe calibration	0.0	-99.9/ -179.8	99.9/ 179.8	Δ °C/ Δ °F
S	/LS	Condensing pressure probe lower limit	-1/ -14.5	-1/ -14.5	/US	barg/ psig

User	Code	Description	Def.	Min.	Max.	UOM
S	/LT	Suction pressure probe lower limit, line 1	-1/ -14.5	-1/ -14.5	/UT	barg/ psig
S	/LTB	Suction pressure probe lower limit, line 2	-1/ -14.5	-1/ -14.5	/UTB	barg/ psig
S	/US	Condensing pressure probe upper limit	34.5/ 500.3	/LS	200/ 2900 (*)	barg/ psig
S	/UT	Suction pressure probe upper limit, line 1	9.3/ 134.8	/LT	45/ 652.5	barg/ psig
S	/UTB	Suction pressure probe upper limit, line 2	9.3/ 134.8	/LTB	45/ 652.5	barg/ psig

Tab. 2.e

Parameter /2 can be used to filter the probe readings. Higher values of /2 give a more stable value yet a longer delay. The reading of each probe can be adjusted by an offset, set using the corresponding '/C' parameters. The minimum and maximum values of the pressure probes can be set using parameters /LS, /LT, /LTB, /US, /UT, /UTB.

🔔 **Notice:** any conflicts between several inputs on the same physical channel must be verified by the manufacturer of the unit; if undesired behaviour is seen, carefully check the configuration of the inputs and outputs.

🔔 **Notice:** The maximum value of the probe channel assignment depends on the size of the selected hardware.

2.10.2 Digital inputs

µRack comes with 5 digital inputs on the panel model and 6 on the DIN version.

Below is the list of parameters used to configure the digital inputs; setting the value 0 disables the specific input:

User	Code	Description	Def.	Min.	Max.	UOM
S	DiA	Assign external alarm digital input (0 = function disabled; 1 = ID1, 2 = ID2; ...; 6 = ID6)*	0	0	6	-
S	DiA1	Assign compressor 1 digital input, line 1 - see DiA	1	0	6	-
S	DiA2	Assign compressor 2 digital input, line 1 - see DiA	2	0	6	-
S	DiA3	Assign compressor 3 digital input, line 1 - see DiA	0	0	6	-
S	DiA4	Assign compressor 4 digital input, line 1 - see DiA	0	0	6	-
S	DiAA	Assign compressor 1 digital input, line 2 - see DiA	0	0	6	-
S	DiAB	Assign compressor 2 digital input, line 2 - see DiA	0	0	6	-
S	DiF**	Assign remote On/Off digital input, line 1 - see DiA	0	0	6	-
S	DiFB**	Assign remote On/Off digital input, line 2 - see DiA	0	0	6	-
S	DiLv	Assign liquid level digital input - see DiA	0	0	6	-
S	DiSC	Assign set point compensation digital input - see DiA	0	0	6	-
S	DiT	Assign low pressure digital input, line 1 - see DiA	0	0	6	-
S	DiTB	Assign low pressure digital input, line 2 - see DiA	0	0	6	-
S	DiY	Assign high pressure digital input - see DiA	5	0	6	-
S	DivA	Assign fan 1 digital input - see DiA	3	0	6	-
S	DivB	Assign fan 2 digital input - see DiA	4	0	6	-
S	DivC	Assign fan 3 digital input - see DiA	0	0	6	-
S	DivD	Assign fan 4 digital input - see DiA	0	0	6	-
S	Dib	Assign delayed external alarm digital input - see DiA	0	0	6	-
S	DiS	Assign generic alarm digital input - see DiA	0	0	6	-
S	RiA	External alarm digital input logic (0 = reverse; 1 = direct)	1	0	1	-
S	RiA1	Compressor 1 digital input logic, line 1 - see RiA	1	0	1	-
S	RiA2	Compressor 2 digital input logic, line 1 - see RiA	1	0	1	-
S	RiA3	Compressor 3 digital input logic, line 1 - see RiA	1	0	1	-
S	RiA4	Compressor 4 digital input logic, line 1 - see RiA	1	0	1	-
S	RiAA	Compressor 1 digital input logic, line 2 - see RiA	1	0	1	-
S	RiAB	Compressor 2 digital input logic, line 2 - see RiA	1	0	1	-
S	riB	Delayed external alarm digital input logic - see RiA	1	0	1	-
S	RiF	Remote On/Off digital input logic, line 1 - see RiA	1	0	1	-
S	RiFB	Remote On/Off digital input logic, line 2 - see RiA	1	0	1	-
S	RiLv	Liquid level digital input logic - see RiA	1	0	1	-
S	RiSC	Set point compensation digital input logic - see RiA	1	0	1	-
S	riS	Generic alarm digital input logic - see RiA	1	0	1	-
S	RiT	Low pressure digital input logic, line 1 - see RiA	1	0	1	-
S	RiTB	Low pressure digital input logic, line 2 - see RiA	1	0	1	-
S	RiY	High pressure digital input logic - see RiA	1	0	1	-
S	RivA	Fan 1 digital input logic - see RiA	1	0	1	-
S	RivB	Fan 2 digital input logic - see RiA	1	0	1	-
S	RivC	Fan 3 digital input logic - see RiA	1	0	1	-
S	RivD	Fan 4 digital input logic - see RiA	1	0	1	-

Tab. 2.f

(*) digital input ID6 is only available on the DIN version.

(**) To use one input to switch off both lines, parameters DiF and DiFB can be configured on the same channel.

🔔 **Notice:** any conflicts between several inputs on the same physical channel must be verified by the manufacturer of the unit; if undesired behaviour is seen, carefully check the configuration of the inputs and outputs.

🔔 **Notice:** the maximum value of the digital inputs depends on the selected hardware.

The digital input logic can be set using the corresponding 'Ri' parameters.'

2.10.3 Analogue outputs

Below is the list of parameters used to configure the analogue outputs:

User	Code	Description	Def.	Min.	Max.	UOM
S	/Ai	Assign inverter compressor 1 analogue output, line 1 – see /AD	0	0	2	-
S	/AiB	Assign inverter compressor 1 analogue output, line 2 – see /AD	0	0	2	-
S	/AD	Assign analogue output for generic modulating function 0 = function disabled; 1 = analogue output 1 (Y1); 2 = analogue output 2 (Y2).	0	0	2	-
S	/AE	Assign analogue output for inverter fan - see /AD	0	0	2	-
S	Ao1M	Maximum output value for Y1	10	Ao1n	10	-
S	Ao1n	Minimum output value for Y1	0	0	Ao1M	-
S	Ao2M	Maximum output value for Y2	10	Ao2n	10	-
S	Ao2n	Minimum output value for Y2	0	0	Ao2M	-

Tab. 2.g

The minimum and maximum values of outputs Y1 and Y2 can be set using parameters Ao1M, Ao1n, Ao2M, Ao2n.

Notice: any conflicts between several inputs on the same physical channel must be verified by the manufacturer of the unit; if undesired behaviour is seen, carefully check the configuration of the inputs and outputs.

2.10.4 Digital outputs

Below is the list of parameters used to configure the digital outputs:

User	Code	Description	Def.	Min.	Max.	UOM
S	DoB	Assign global alarm digital output - see DoA1	5	0	6	
S	DoH	Assign serious alarm digital output - see DoA1	0	0	6	
S	DoA1	Assign compressor 1 digital output, line 1 (0 = function disabled; 1 = NO1, 2 = NO2; ...; 6 = NO6)	1	0	6	
S	DoA2	Assign compressor 2 digital output, line 1 - see DoA1	2	0	6	
S	DoA3	Assign compressor 3 digital output, line 1 - see DoA1	0	0	6	
S	DoA4	Assign compressor 4 digital output, line 1 - see DoA1	0	0	6	
S	DoAA	Assign compressor 1 digital output, line 2 - see DoA1	0	0	6	
S	DoL1	Assign compressor 1 unloader digital output 1, line 1 (*) - see DoA1	0	-2	6	
S	DoL2	Assign compressor 1 unloader digital output 2, line 1 - see DoA1	0	-2	6	
S	DoM1	Assign compressor 1 unloader digital output 1, line 2 (*) - see DoA1	0	-2	6	
S	DoAB	Assign compressor 2 digital output, line 2 - see DoA1	0	0	6	
S	DoCH	Assign crankcase heater digital output - see DoA1	0	0	6	
S	DoT	Assign fan 1 digital output - see DoA1	3	0	6	
S	DoT2	Assign fan 2 digital output - see DoA1	4	0	6	
S	DoT3	Assign fan 3 digital output - see DoA1	0	0	6	
S	DoT4	Assign fan 4 digital output - see DoA1	0	0	6	
S	DoS	Assign generic step function digital output - see DoA1	0	0	6	
S	RoB	Global alarm digital output logic - see RoA1	0	0	1	
S	RoH	Serious alarm digital output logic - see RoA1	0	0	1	
S	RoA1	Compressor 1 digital output logic, line 1 (0 = reverse; 1 = direct)	0	0	1	
S	RoA2	Compressor 2 digital output logic, line 1 - see RoA1	0	0	1	
S	RoA3	Compressor 3 digital output logic, line 1 - see RoA1	0	0	1	
S	RoA4	Compressor 4 digital output logic, line 1 - see RoA1	0	0	1	
S	RoAA	Compressor 1 digital output logic, line 2 - see RoA1	0	0	1	
S	RoAB	Compressor 2 digital output logic, line 2 - see RoA1	0	0	1	
S	RoM1	Compressor 1 unloader digital output 1 logic, line 2 - see RoA1	0	0	1	
S	RoCH	Crankcase heater digital output logic - see RoA1	0	0	1	
S	RoT	Fan 1 digital output logic - see RoA1	0	0	1	
S	RoT2	Fan 2 digital output logic - see RoA1	0	0	1	
S	RoT3	Fan 3 digital output logic - see RoA1	0	0	1	
S	RoT4	Fan 4 digital output logic - see RoA1	0	0	1	
S	RoS	Generic step function digital output logic - see RoA1	0	0	1	

Tab. 2.h

(*) For Digital Scroll™ modulating compressors, the unloader output must be configured on an SSR output (ADVANCED model), or alternatively external SSR relays with an input voltage compatible with the 0-10V outputs Y1 and Y2 can be connected (BASIC and MEDIUM models). Parameter values -1 and -2 correspond to analogue outputs 1 and 2 respectively.

The digital output logic can be set using the corresponding 'Ro' parameters.'

Notice: the maximum value of the digital inputs depends on the selected hardware.

3. COMMISSIONING

Once the electrical connections have been completed (see "Installation") and the power supply has been connected, the operations required for commissioning the controller depend on the type of interface used, however essentially involve setting the initial configuration parameters and where necessary the date/time. The parameters can be set on a smartphone (via APPLICA app), using configuration software (APPLICA desktop, Spark, Sparkly) or from the user terminal. The parameters to be imported are shown under "Unit set-up parameter list".

3.1 Commissioning via smartphone

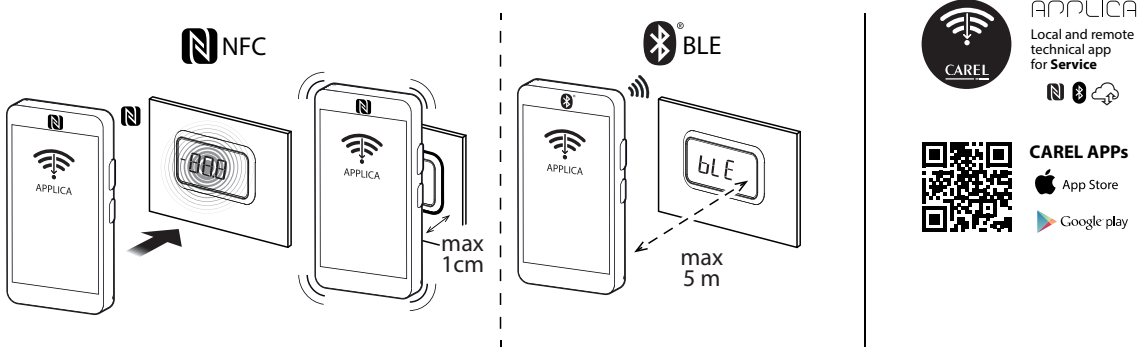

Fig. 3.a

The "Applica" app can be used to configure the controller from a mobile device (smartphone, tablet), via NFC (Near Field Communication) and Bluetooth (BLE). Users can both configure the commissioning parameters and set groups of preset parameters according to specific needs (recipes). Supported devices: Android 7, iOS 11; Bluetooth™ 4.0, and higher.

Once "Applica" has been installed and opened, proceed as follows:

- For NFC devices, move the mobile device near to the μRack user terminal (the position of the NFC antenna on the mobile device must be identified in order to place it over the display): wait for the signal that the device has been read.
- For Bluetooth devices, select the "SCAN BLUETOOTH" option, then choose the device from the list.

- 🔔 **Notice:** make sure NFC or Bluetooth™ have been enabled.
- 🔔 **Notice:** Some smartphones may experience problems if location is not enabled.
- 🔔 **Notice:** During Bluetooth™ connection, the μRack user terminal is disabled and shows the message "bLE".

3.1.1 Applica: Configuration wizard

1. If the unit has not yet been configured, when connecting to the controller from a mobile device, a prompt will be shown to start the "Wizard" procedure. If the procedure is not started, selecting "Skip", the default configuration is automatically applied and the Homepage will be displayed;
2. Complete the unit configuration by pressing the PREV / NEXT buttons to scroll through all of the configuration parameter pages;

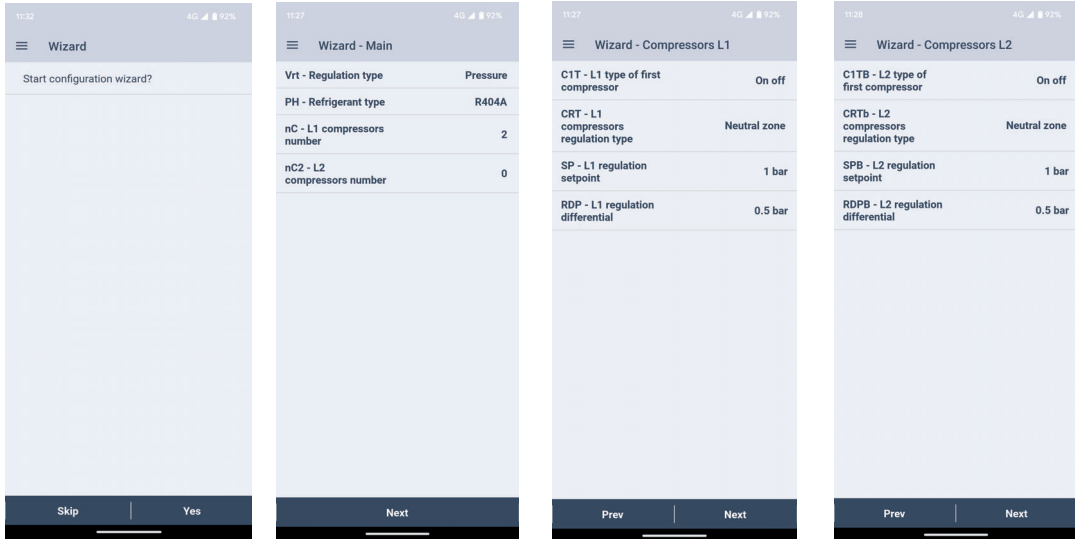



3. Apply the parameters configured via NFC/Bluetooth to the controller.

Notice: for NFC connection only, at the end of the procedure the mobile device will need to be moved closer to the controller in order to save the parameter configuration.

3.1.2 Applica: date and time setting

Applica includes a feature for setting the date and time on μ Rack in just one simple step, copying the values from the mobile device.

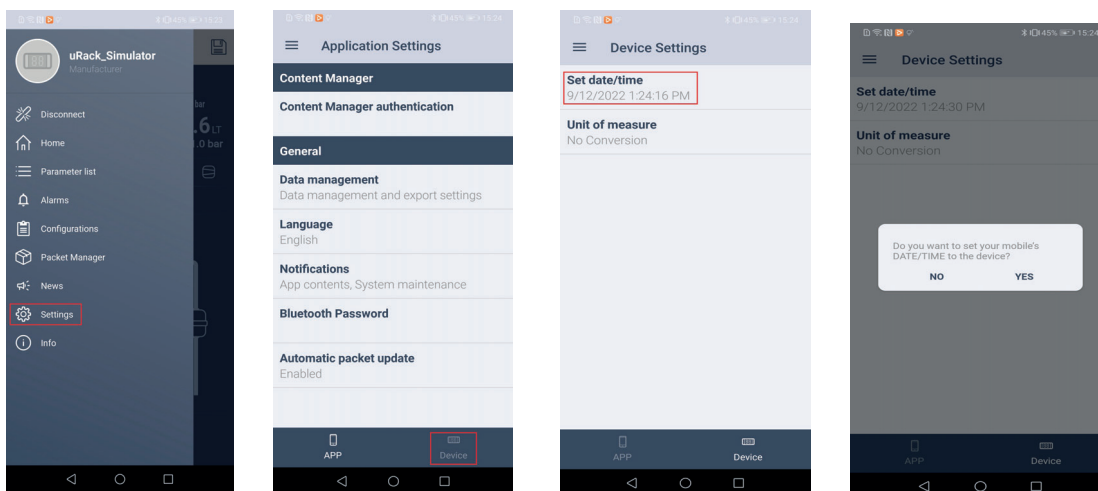

Procedure:

1. open Applica on the mobile device;
2. access the controller via NFC or Bluetooth, entering your profile credentials;
3. access the menu on the command bar at the top left;
4. select "set date/time":
5. confirm;
6. with an NFC connection, move the device near to the user terminal to write the copied values.

Note: with a Bluetooth connection, the values are copied on confirmation.

3.1.3 Applica: save configuration

Applica can save the unit configuration and then apply it to other units.

Procedure:

1. open Applica on the mobile device;
2. access the controller via NFC or Bluetooth, using the "Service" or "Manufacturer" profile credentials;
3. select the "Save configuration" button at the top right;
4. enter the configuration name, then click OK.

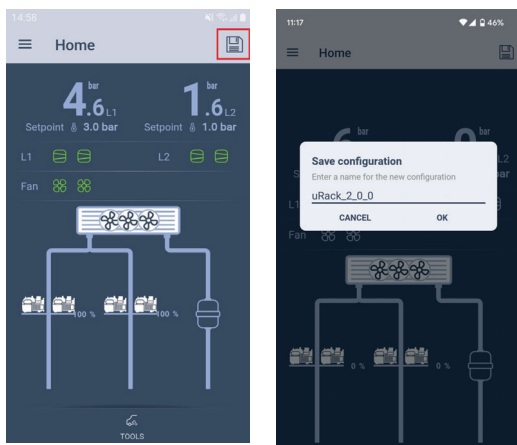

3.1.4 Applica: import/export configuration

Applica can import and export previously saved configurations.

Import configuration procedure:

1. Open Applica on the mobile device;
2. access the controller via NFC or Bluetooth, using the "Service" or "Manufacturer" profile credentials;
3. access the "Configurations" section from the hamburger menu;

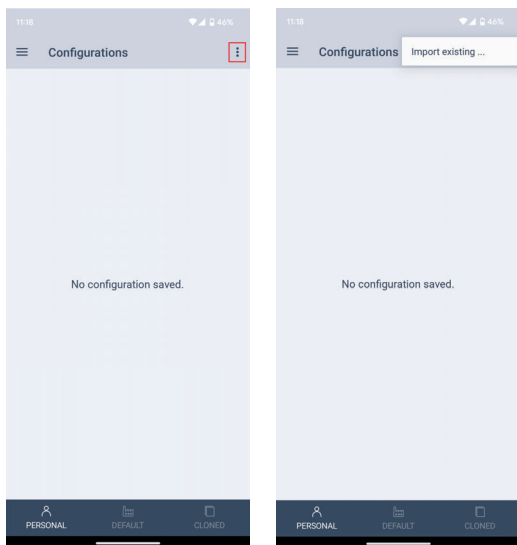

4. click the toolbar menu button at the top right, then click "Import existing";
5. choose and select the configuration to be imported from the phone's file manager.

Export configuration procedure:

1. Open Applica on the mobile device;
2. access the controller via NFC or Bluetooth, using the "Service" or "Manufacturer" profile credentials;
3. access the "Configurations" section from the hamburger menu;
4. the previously saved configurations will be displayed, click the toolbar menu button for the configuration to be exported;

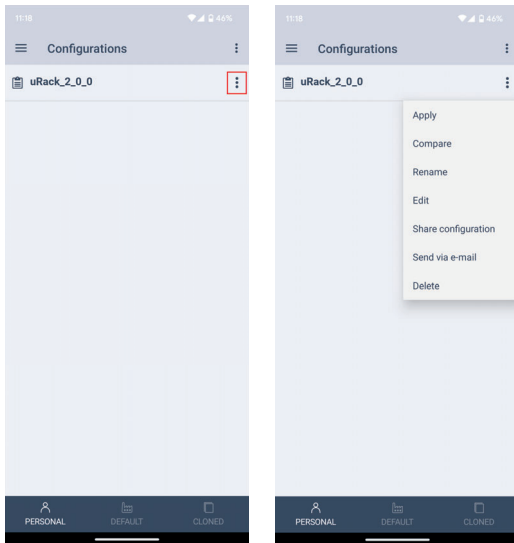

5. select the "Share configuration" button and choose how to share the configuration.

3.2 Via PC (serial/USB): with configuration tool

3.2.1 Applica Desktop

Applica Desktop is a program intended for manufacturers and installers of units fitted with the μ Rack controller. It can be downloaded from ksa.carel.com. The Applica Desktop offers the possibility to:

- access the controller using the assigned profile;
- create configurations;
- apply configurations;
- clone a unit configuration, i.e. copy all of the unit's parameter values;
- complete the commissioning procedure;
- troubleshoot any problems on the unit.

Notice:

- Applica Desktop can be used as an alternative to the Applica app, and requires an internet connection;
- For the physical connection to the BMS port on μ Rack, use the USB/RS485 converter P/N CVSTDUMORO

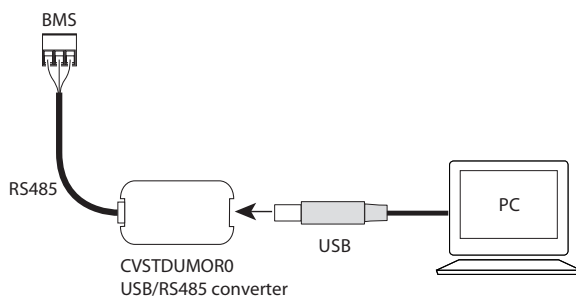

Fig. 3.b

3.2.2 Spark: configuration and commissioning software

Spark is configuration software for laptops that provides the following functions:

- configure access and password levels;
- change parameter sets and create custom read/write lists to upload to the device;
- add languages and parameter descriptions;
- view the trends of physical quantities in real time, with the possibility to save data in Excel format.

In order to carry out the operations mentioned above, a specific “workspace” (extension .spark) is required; this can be downloaded from ksa.carel.com.

Notice: the workspace is specific for each firmware version; the correct combination of file-controller firmware version is required for correct communication.

For the electrical connection, use the USB/RS485 converter CVSTDUMOR0.

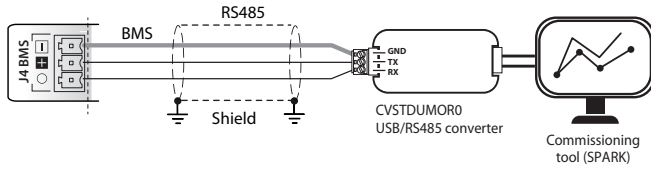

Fig. 3.c

For models without BMS port option, the USB/ID converter BXOPZIOWD000 can be used, connecting to digital input ID2 and completing the specific procedure on Spark.

3.2.3 Sparkly: command-line configuration and commissioning software

Sparkly is the command-line version of the configuration tool, and can be used for configuring and commissioning μ Rack. Contact CAREL for support.

3.2.4 Applica Desktop: commissioning

1. Connect to the BMS port on the μ Rack controller, as shown in Figure 3.b
2. Open Applica Desktop; a window will be opened with the right part of the top bar as shown in the figure

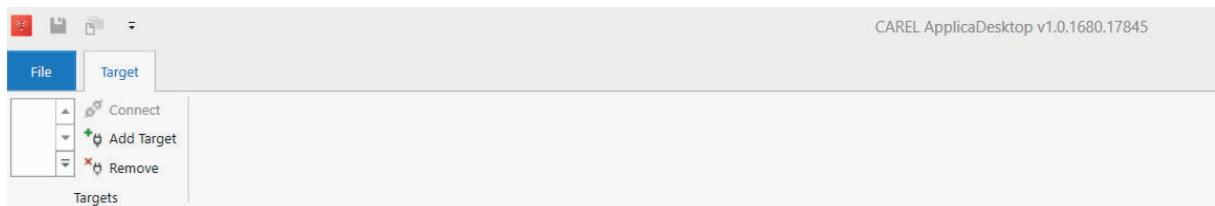

Fig. 3.d

3. Select “Add target” and assign it a meaningful name (e.g. “ μ Rack”)
4. In the “COM Port” field, enter the COM port used for the USB connection to the USB/RS485 converter. The COM port depends on the USB port used; to find it, click on “Windows Tools”, “Device Manager”, then “COM port”
5. Configure the connection parameters (Baudrate=19200, Bits=8, Parity=None, Stop Bits=Two, Serial Node=1) as shown in the figure (the data are saved automatically)
6. Select “Connect” to connect to the μ Rack (which must be powered on)
7. Enter your profile credentials
8. Set the commissioning parameters

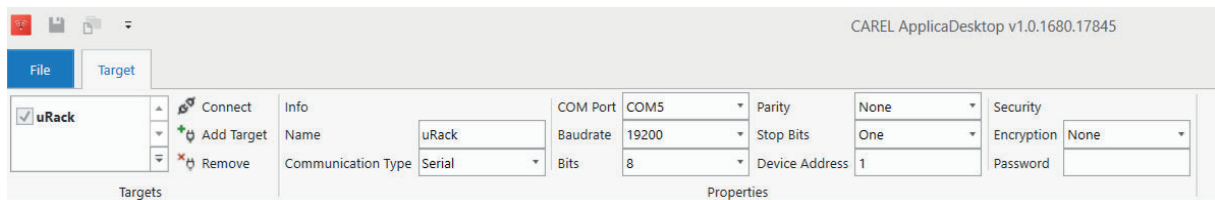

Fig. 3.e

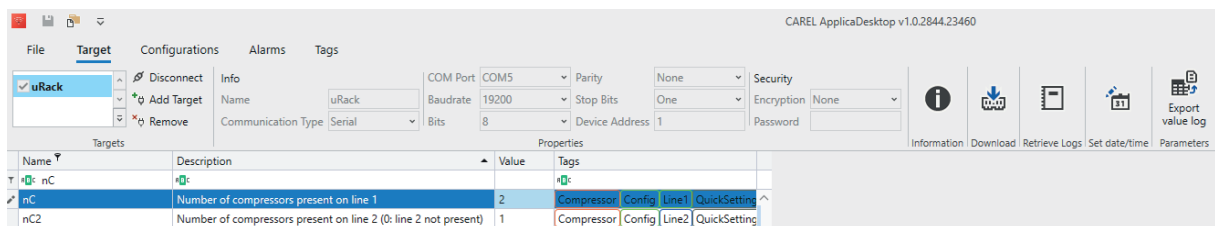

Fig. 3.f

3.2.5 Applica Desktop: date and time setting

Applica Desktop can set the date and time on μ Rack in just one simple step, copying the values from the PC to the controller.

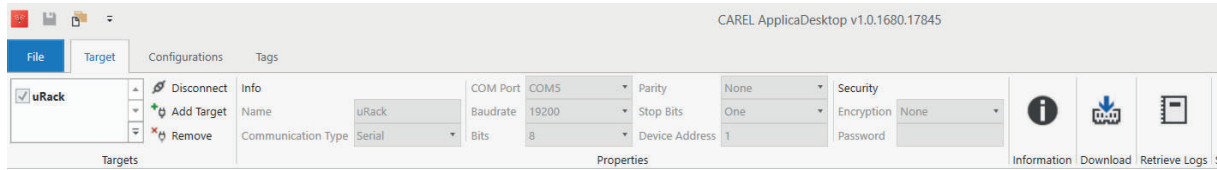
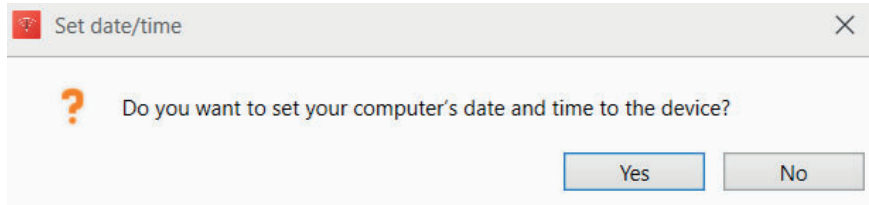

Fig. 3.g

Procedure:

1. Once connected, select "Set date&time";
2. In the pop-up window, confirm synchronisation of the time and date on μ Rack with the PC



3.3 Via user terminal

Procedure:



1. Power on the controller and wait for the display to show the first parameter Vrt (control based on temperature or pressure);
2. press PRG to enable parameter setting (the value will flash);

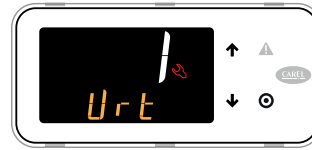

3. press UP/DOWN to modify the value

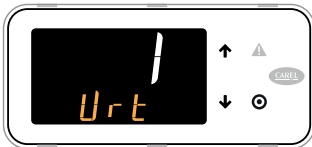

4. press PRG to save the value (the value will stop flashing and the red service icon will go off);

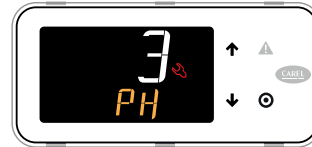

5. press UP/DOWN to go to the next parameter;
6. repeat points 2 to 5 for all commissioning parameters

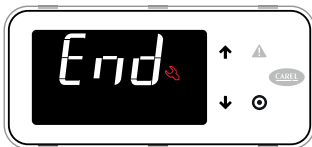

7. press PRG to end the configuration procedure (wizard); once all the parameters have been configured ("service" icon no longer displayed), pressing PRG ends the configuration procedure (wizard);



8. wait for the standard display to be shown.

3.4 Unit set-up parameter list

3.4.1 Unit parameters

🔔 **Notice:** follow the order shown in the table to configure the Unit set-up parameters.

User	Code	Description	Def.	Min.	Max.	UOM
S	vrT	Control by pressure or temperature (0= pressure; 1= temperature)	0	0	1	-
M	PH	Type of refrigerant used in the unit	3	0	47	-
		0:Custom 8: R600 16: R413A 24: HTR01 32: R447A 40: R454B 1: R22 9: R600a 17: R422A 25: HTR02 33: R448A 41: R458A 2: R134a 10: R717 18: R423A 26: R23 34: R449A 42: R407H 3: R404A 11: R744 19: R407A 27: HFO1234yf 35: R450A 43: R454A 4: R407C 12: R728 20: R427A 28: HFO1234ze 36: R452A 44: R454C 5: R410A 13: R1270 21: R245Fa 29: R455A 37: R508B 45: R470A 6: R507A 14: R417A 22: R407F 30: R170 38: R452B 46: R515B 7: R290 15: R422D 23: R32 31: R442A 39: R513A 47: R466				
M	nC	Number of compressors in circuit 1	2	0	4	-
M	C1T	First compressor type, line 1: 0= ON-OFF 2= Digital Scroll™ 4= three stages 33/66/100 1= inverter 3= two stages 50/100	0	0	4	-
S	CRT	Compressor control type, line 1 (0= P+; 1= dead band)	1	0	1	-
U	SP	Control set point, line 1	1/ 14.5	SPL	SPH	barg/ psig
M	nC2	Number of compressors, line 2 (0= line 2 not present)	0	0	2	-
M	C1TB	First compressor type, line 1 – see C1T	0	0	4	-
S	CRTb	Compressor control type, line 2 (0= P+; 1= dead band)	1	0	1	-
U	SPB	Control set point, line 2	1/ 14.5	SPLB	SPHB	barg/ psig
S	RDPB	Control differential, line 2	0.5/ 7.2	0	20/ 290	Δbarg/ Δpsig
M	nF	Number of fans	2	0	4	-
M	IFL1	Type of fans used on the unit (0= ON/OFF 1= Inverter)	0	0	1	-
S	Frt	Fan control type (0= P+; 1= dead band)	1	0	1	-
U	STF	Condenser fan control set point	15.5/ 224.8	STFL	STFH	barg/ psig
S	RDF	Condenser fan control differential	3/ 43.5	0	20/ 290	Δbarg/ Δpsig

Tab. 3.i

3.4.2 I/O configuration

For the description of the following parameters, see the chapter on Input/output configuration in of this document

User	Code	Description	Def.	Min.	Max.	UOM
S	/FT	Assign line 1 suction pressure probe channel – see /F3	4	0	7*	-
S	/FD	Assign line 1 suction temperature probe channel – see /F3	3	0	7*	-
S	/FTB	Assign line 2 suction pressure probe channel – see /F3	0	0	7*	-
S	/FDB	Assign line 2 suction temperature probe channel – see /F3	0	0	7*	-
S	/FS	Assign condensing pressure probe channel – see /F3	5	0	7*	-
S	/F3	Assign outside temperature probe channel (0= function disabled; 1= S1; 2= S2; ...; 7= S7)	0	0	7*	-
S	DiT	Assign low pressure digital input, line 1 - see DiA	0	0	6*	-
S	DiTB	Assign low pressure digital input, line 2 - see DiA	0	0	6*	-
S	DiY	Assign high pressure digital input - see DiA	5	0	6*	-
S	DoA1	Assign compressor 1 digital output, line 1 (0 = function disabled; 1= NO1, 2= NO2; ...; 6= NO6)	1	0	6*	-
S	...	(Number of compressors based on the configuration)	-	-	-	-
S	/Fo	Assign line 1 discharge temperature probe channel – see /F3	6	0	7	-
S	/Fob	Assign line 2 discharge temperature probe channel – see /F3	0	0	7	-
S	DiA	Assign external alarm digital input: 0 = function disabled; 1= ID1, 2= ID2; ...; 6= ID6.	0	0	6	-
S	DiA1	Assign compressor 1 digital input, line 1 - see DiA	1	0	6	-
S	...	(Number of compressors based on the configuration)	-	-	-	-
S	DivA	Assign fan 1 digital input - see DiA	3	0	6	-
S	...	(Number of fans based on the configuration)	-	-	-	-
S	DoH	Assign serious alarm digital output - see DoA1	0	0	6	-
S	DoT	Assign fan 1 digital output - see DoA1	3	0	6	-
S	...	(Number of fans based on the configuration)	-	-	-	-
S	DoB	Assign global alarm digital output - see DoA1	5	0	6	-
S	/Ai	Assign inverter compressor 1 analogue output, line 1 – see /AD	0	0	2	-
S	/AiB	Assign inverter compressor 1 analogue output, line 2 – see /AD	0	0	2	-
S	/AE	Assign analogue output for inverter fan - see /AD	0	0	2	-

Tab. 3.j

(*) The maximum value depends on the size of the selected hardware

4. USER INTERFACE

4.1 Introduction

µRack uses the user terminal to display the alarms, the main variables and to set the unit set points (User level) and manual functions (Service level). The terminal has a 7-segment LED display with two rows: the top row is 3-digit plus sign and decimal point; the bottom row is 4-digit plus sign (this can also display the hour format -hh:mm and date - MM:DD). There is a buzzer, 14 operating icons and 4 buttons for scrolling and setting the parameters. The terminal has NFC (Near Field Communication) and Bluetooth™ (versions without BLE are available) connectivity for interaction with mobile devices (on which the Carel “Applica” app has been installed, available on Google Play for the Android operating system and Apple store for iOS).

Notice: access levels: U=User; S=Service; M=Manufacturer See the parameter table.

The unit of measure on the display can be changed via parameter UoM, accessed at a Service level, including in the direct access functions menu.

User	Code	Description	Def.	Min	Max	UOM
S	/5	Unit of measure - 0=°C/barg 1=°F/psig	0	0	1	-
U	H8	Enable buzzer	1	1	-	0

Tab. 4.a

The information and parameters accessible from the terminal and from the Applica app depend on the access level and the unit configuration parameters.

4.2 User terminal

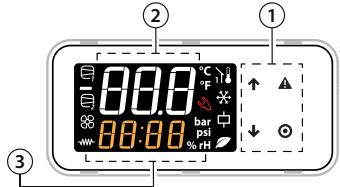

Fig. 4.a

Key:

1	Keypad
2	Main field
3	Device status and operating mode icons

Tab. 4.b

Notice: the user terminal only allows access to certain parameters at the User and Service levels: to access all of the Service and Manufacturer parameters, use the Carel Applica app or the configuration and Applica Desktop commissioning software.

4.2.1 Keypad

Button	Description	Function
	UP	<ul style="list-style-type: none"> When scrolling: go to the previous parameter In programming mode: increase the value
	DOWN	<ul style="list-style-type: none"> When scrolling: go to the next parameter In programming mode: decrease in value
	Alarm	<p>Main menu:</p> <ul style="list-style-type: none"> pressed briefly twice: display the unit dashboard <ul style="list-style-type: none"> Pressed briefly: display active alarms and mute buzzer Pressed and held (3 s): reset alarms
	PRG	<ul style="list-style-type: none"> Pressed and held (3 s): access the programming menu <p>When scrolling:</p> <ul style="list-style-type: none"> access parameter programming mode: <ul style="list-style-type: none"> pressed briefly: confirm value pressed and held (3 s): return to the main menu

Tab. 4.c

4.2.2 Icons

The icons indicate the device operating status and operating modes, as shown in the following table.

Icon	Function	On	Flashing
	Compressor status, line 1	At least 1 compressor on	Prevent or power limitation due to active safety procedure
	Compressor status, line 2	At least 1 compressor on	Prevent or power limitation due to active safety procedure
	Condenser fan status	At least 1 fan on	High pressure prevention
	Crankcase heater	Active	-
	Operating mode	Floating condenser active	-
		Low superheat or liquid return	Safety procedure active for low superheat protection
		Floating suction active	-
	Service	Request on exceeding operating hour threshold; Wizard on going	Serious alarm, action required by qualified personnel

Tab. 4.d

4.3 Standard display

At start-up, the user terminal briefly shows “NFC”, indicating that the terminal NFC interface is available for communication with mobile devices, then the software version (e.g.: µRack 1.0), and then the standard display is shown.

The standard display shows:

- on the top row: the suction pressure/temperature in line 1;
- in the bottom row: the condensing pressure/temperature or, if configured, the suction pressure/temperature in line 2.

🔊 **Notice:** “bLE” flashes on the display during “Bluetooth” communication.

4.3.1 Dashboard – 7-segment display

From the main menu, press DOWN twice and confirm by pressing PRG when the message “SYN” is shown, so as to access information on the status of the devices and the temperature, superheat value, etc. in the two circuits:

- “CL1” current compressor capacity in line 1, followed by the status of each compressor in the line;
- “CL2” current compressor capacity in line 2, followed by the status of each compressor in the line;
- “FAn” current capacity of the condenser fans;
- “TGS” suction temperature line 1;
- “SHL1” superheat line 1.

Example



1. Go to the standard display
2. Press DOWN twice



3. Press PRG to access the dashboard



4. Display the current capacity of line 1 as a %



5. Press DOWN: CL1 indicates the status of the individual compressors in line 1: () compressor off, (o) compressor at part load and (O) compressor on at maximum capacity



6. Press DOWN: CL2 indicates the current capacity of line 2 as a %



7. Press DOWN: CL2 indicates the status of the individual compressors in line 2: () compressor off, (o) compressor at part load and (O) compressor on at maximum capacity

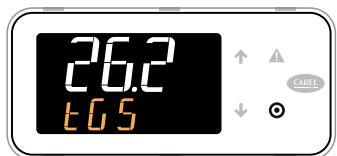

8. Press DOWN: tGS indicates the suction temperature in line 1



9. To return to the standard display, press PRG (corresponding to ESC)

4.3.2 Programming mode

Go to the standard display and press PRG for 3 seconds to enter programming mode.

The controller can be programmed in two levels, with access to different parameters based on the password entered (see the parameter table):

- service (password = 44)
- manufacturer (password = 77)

The user profile does not need a password and has reduced parameter access

Code	Description	Def.	UOM	Min	Max	Lev.
PDS	Service password	44	-	0	999	M
PDM	Manufacturer password	77	-	0	999	M

Tab. 4.e

Procedure

Press:

- PRG to access parameters with password protection (manufacturer psw 77, installer psw 44 - the passwords are valid for access from the display, Applica Mobile app and Applica Desktop app);
- UP and DOWN to scroll and set the parameters;
- PRG to change the parameter value and save the changes;
- PRG (3 s) or ESC to return to the standard display.



1. Go to the standard display



2. Press PRG for 3 seconds: the first digit of the password flashes; set the value, press PRG. The second digit now flashes; enter the other digits to complete the password.



3. Press PRG: if the password is correct, the first parameter category is shown: Un1 (=Unit Status)



4. Press PRG: the first parameter is displayed: ON (Manual control pump 1)

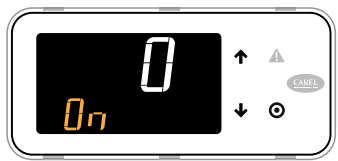

5. Press PRG: the value flashes; press UP/DOWN to change the value; PRG to confirm.

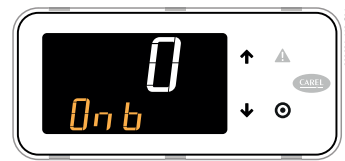

6. Press UP/DOWN to display the other parameters.



7. Press PRG for 3 seconds or alternatively, in the parameter level press ESC and press PRG to return to the parameter categories

4.3.3 Programming menu

First level	Second level														
	<p>Category Un1 (Unit Status): all of the parameters relating to the unit status.</p>														
	<p>Category IO (Input/Output): all of the parameters relating to the configuration of the inputs and outputs</p> <table border="0"> <tr><td>DIn</td><td>Digital inputs</td></tr> <tr><td>Ain</td><td>Analogue inputs</td></tr> <tr><td>dO</td><td>Digital outputs</td></tr> <tr><td>AO</td><td>Analogue outputs</td></tr> <tr><td>MAn</td><td>Manual mode</td></tr> <tr><td>tSt</td><td>Test mode</td></tr> <tr><td>ESC</td><td>Return to the previous level</td></tr> </table>	DIn	Digital inputs	Ain	Analogue inputs	dO	Digital outputs	AO	Analogue outputs	MAn	Manual mode	tSt	Test mode	ESC	Return to the previous level
DIn	Digital inputs														
Ain	Analogue inputs														
dO	Digital outputs														
AO	Analogue outputs														
MAn	Manual mode														
tSt	Test mode														
ESC	Return to the previous level														
	<p>Category CL1 (Compressors Line 1): all of the parameters relating to the configuration and control of the compressors on line 1.</p> <table border="0"> <tr><td>rEG</td><td>Control</td></tr> <tr><td>CFG</td><td>Configuration</td></tr> <tr><td>ALM</td><td>Alarms</td></tr> <tr><td>ESU</td><td>Energy saving</td></tr> <tr><td>ESC</td><td>Return to the previous level</td></tr> </table>	rEG	Control	CFG	Configuration	ALM	Alarms	ESU	Energy saving	ESC	Return to the previous level				
rEG	Control														
CFG	Configuration														
ALM	Alarms														
ESU	Energy saving														
ESC	Return to the previous level														



Category CL2 (Compressors Line 2): all of the parameters relating to the configuration and control of the compressors on line 2.

- rEG Control
- CFG Configuration
- ALM Alarms
- ESU Energy saving
- ESC Return to the previous level



Category FAn (Condenser fans): all of the parameters relating to the configuration and control of the condenser fans.

- rEG Control
- CFG Configuration
- ALM Alarms
- ESU Energy saving
- ESC Return to the previous level



Category OeH (Other Functions): all of the parameters relating to the accessory functions for the compressors or other devices on the unit

- OIL Oil recovery
- dSS Double line synchronisation
- ESC Return to the previous level



Category SAF (Safeties): all of the parameters concerning unit safety

- ALM Alarms
- PrU Password
- LOG Logs
- ESC Return to the previous level



Category StG (Settings): all of the parameters relating to configuration of the controller for communication or RTC

- CLO Clock
- PSd Prevention
- bMS BMS
- FbS FieldBus
- ESC Return to the previous level



Press PRG for 3 sec or alternatively, in the parameter level select ESC and press PRG to return to the parameter categories

Notice:

- a higher level password also allows access to the parameters enabled by a lower level password; for example, the service password also provides access to the user parameters;
- if no button is pressed, after around 3 minutes the terminal will automatically return to the standard display and the password will need to be entered again to access parameter programming.

5. FUNCTIONS

5.1 Unit ON/OFF

- The unit can be switched on and off from:
- User terminal (parameters on and onb)
 - Supervisor
 - Digital input (parameters DiF and DiFB)
 - Serious alarm

All these actions have the same priority, and therefore only one of the conditions is necessary to shut down the unit. On-Off from user terminal and via digital input are separate for line 1 and line 2; if both lines are off, the condensing stage is also off, while one suction line needs to be on for the condensing stage to be activated.

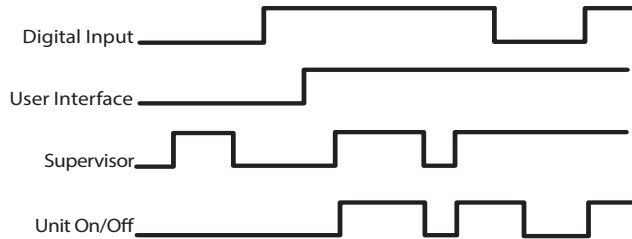

Fig. 5.a

User	Code	Description	Def	Min	Max	UOM
U	on	Line 1 On/Off from keypad (0= Off; 1= On)	0	0	1	-
U	onb	Line 1 On/Off from keypad - see on	0	0	1	-
U	ONK	Enable On/Off from keypad (0= disabled; 1= enabled)	1	0	1	-
S	ons	Enable On/Off from supervisor (0= disabled; 1= enabled)	0	0	1	-
S	DiF	Assign remote On/Off digital input, line 1 - see DiA	0	0	6	-
S	DiFB	Assign remote On/Off digital input, line 2 - see DiA	0	0	6	-

Tab. 5.a

On-Off from keypad and from the supervisor can be enabled using parameters ONK and ons.

5.2 Control

µRack can control the refrigerant saturated suction pressure or temperature for each group of compressors on the unit, as configured using parameter Vrt. The conversion from pressure to saturated temperature is performed considering the type of refrigerant used on the unit, set using parameter PH. All the control probes can be installed on any channel if compatible with the type of probe. See "Installation".

Control can be P + I or dead band, as set using parameters CRT and CRTb.

User	Code	Description	Def	Min	Max	UOM
S	vrt	Pressure or temperature control (0= pressure; 1= temperature)	0	0	1	-
S	CRT	Compressor control type, line 1 (0= P+I; 1= dead band)	1	0	1	-
S	CRTb	Compressor control type, line 2 (0= P+I; 1= dead band)	1	0	1	-
M	PH	Type of refrigerant used in the unit 0: Custom 8: R600 16: R413A 24: HTR01 32: R447A 40: R454B 1: R22 9: R600a 17: R422A 25: HTR02 33: R448A 41: R458A 2: R134a 10: R717 18: R423A 26: R23 34: R449A 42: R407H 3: R404A 11: R744 19: R407A 27: HFO1234yf 35: R450A 43: R454A 4: R407C 12: R728 20: R427A 28: HFO1234ze 36: R452A 44: R454C 5: R410A 13: R1270 21: R245Fa 29: R455A 37: R508B 45: R470A 6: R507A 14: R417A 22: R407F 30: R170 38: R452B 46: R515B 7: R290 15: R422D 23: R32 31: R442A 39: R513A 47: R466	3	0	47	-
S	RDP	Control differential, line 1	0.5/ 7.2	0	20/ 290	Δbarg/ Δpsig
S	RDP_T	Control differential, line 1, expressed as a temperature	5/9	0	99.9/ 179.8	Δ°C/ Δ°F
S	RDPB	Control differential, line 2	0.5/ 7.2	0	20/ 290	Δbarg/ Δpsig
S	RDPB_T	Control differential, line 2, expressed as a temperature	5/9	0	99.9/ 179.8	Δ°C/ Δ°F
U	SP	Control set point, line 1	1/14.5	SPL	SPH	barg/ psig
U	SPt	Control set point, line 1, expressed as a temperature	1/33.8	SPL_T	SPH_T	°C/°F
U	SPB	Control set point, line 2	1/14.5	SPLB	SPHB	barg/ psig
U	SPBt	Control set point, line 2, expressed as a temperature	1/33.8	SPLB_T	SPHB_T	°C/°F

Tab. 5.b

The set points can be limited between a minimum and a maximum value that can be set using parameters SPH, SPH_T, SPHB, SPHB_T, SPL, SPL_T, SPLB, SPLB_T.

User	Code	Description	Def	Min	Max	UOM
M	SPH	Control set point maximum limit, line 1	9.3/ 134.8	SPL	/UT	barg/psig
M	SPH_T	Control set point maximum limit, line 1, expressed as a temperature	9.3/48.7	SPL_T	99.9 / 211.8	°C/°F
M	SPHB	Control set point maximum limit, line 2	9.3/ 134.8	SPLB	/UTB	barg/psig
M	SPHB_T	Control set point maximum limit, line 2, expressed as a temperature	9.3/48.7	SPLB_T	99.9 / 211.8	°C/°F
M	SPL	Control set point minimum limit, line 1	0.1/1.4	/LT	SPH	barg/psig
M	SPL_T	Control set point minimum limit, line 1, expressed as a temperature	-50/-58	-50/-58	SPH_T	°C/°F
M	SPLB	Control set point minimum limit, line 2	0.1/1.4	/LTB	SPHB	barg/psig
M	SPLB_T	Control set point minimum limit, line 2, expressed as a temperature	-50/-58	-50/-58	SPHB_T	°C/°F

Tab. 5.c

5.2.1 P + I control

The operating principle is normal proportional or proportional + integral (P, P+I) control.

The control set point SP is central, and therefore for proportional control only, operation can be schematised as shown in the following figures:

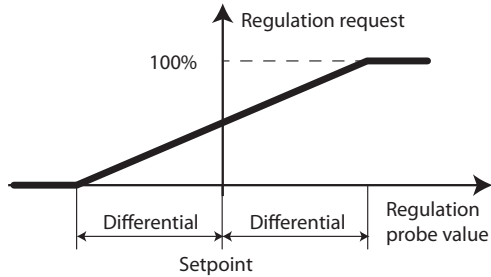

Fig. 5.a

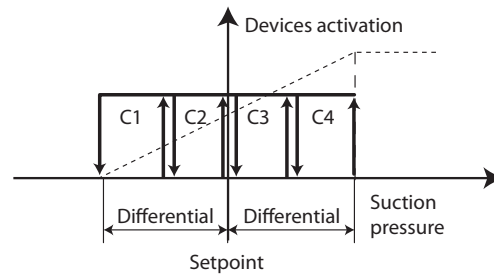

Fig. 5.b

For P+I control, the integral action is summed to the effect of the proportional action described above, making it possible to have a null control error in steady operation, as shown in the figure:

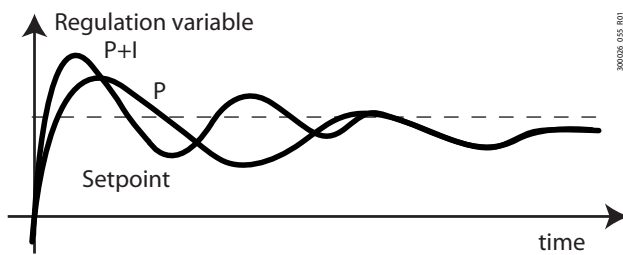

Fig. 5.c

The integral action depends on time and the deviation from the set point. The request will be modified if the control value remains away from the set point for a certain time. The integral time setting Cti represents the rate at which integral control is implemented:

- low values mean a faster response and more intense control actions;
- higher values mean a slower response and more stable control.

It is recommended to not set the integral time too low, in order to avoid instability.

User	Code	Description	Def	Min	Max	UOM
S	Cti	P+I control integral time, line 1	600	0	999	s
S	CTiB	P+I control integral time, line 2	600	0	999	s

Tab. 5.d

5.2.2 Dead band control

The operating principle is schematised in the following figure:

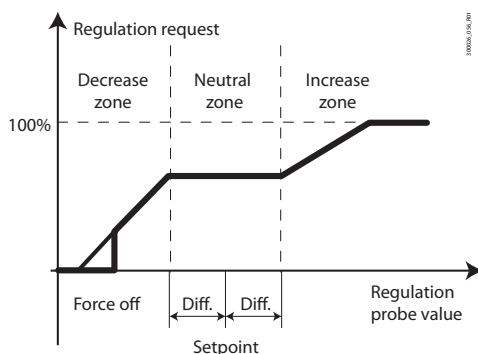

Fig. 5.d

User	Code	Description	Def	Min	Max	UOM
S	CRC	Force off threshold for dead band control, line 1	-1/-14.5	-1/-14.5	20/290	barg/ psig
S	CRC_T	Force off threshold for dead band control, line 1, expressed as a temperature	-1/30.2	-99.9/ -147.8	99.9/ 212.8	°C/°F
S	CRCB	Force off threshold for dead band control, line 2	-1/-14.5	-1/-14.5	20/290	barg/ psig
S	CRCB_T	Force off threshold for dead band control, line 2, expressed as a temperature	-1/30.2	-99.9/ -147.8	99.9/ 212.8	°C/°F
S	RDP	Control differential, line 1	0.5/7.2	0	20/290	Δbarg/ Δpsig
S	RDP_T	Control differential, line 1, expressed as a temperature	5/9	0	99.9/ 179.8	Δ°C/ Δ°F
S	RDPB	Control differential, line 2	0.5/7.2	0	20/290	Δbarg/ Δpsig
S	RDPB_T	Control differential, line 2, expressed as temperature	5/9	0	99.9/ 179.8	Δ°C/ Δ°F
U	SP	Control set point, line 1	1/14.5	SPL	SPH	barg/ psig
U	SPt	Control set point, line 1, expressed as a temperature	1/33.8	SPL_T	SPH_T	°C/°F
U	SPB	Control set point, line 2	1/14.5	SPLB	SPHB	barg/ psig
S	SPBt	Control set point, line 2, expressed as a temperature	1/33.8	SPLB_T	SPHB_T	°C/°F

Tab. 5.e

Inside the dead band, the capacity request sent by the controller is constant, with a value that is assumed will allow the set point to be maintained in those specific operating conditions, and while inside the dead band, no device is switched off or on. In the decrease zone, the request decreases at a rate that depends on the distance from the set point; vice-versa in the increase zone, it increases proportionally.

The following settings are available:

- Fixed times: the request decreases or increases constantly over time.
- Variable times: the request generally decreases or increases faster (based on the settings) as the distance from the set point increases.

Notice: the previous figure refers to increase and decrease with fixed times.

For dead band control, the parameters shown in the figure need to be set:

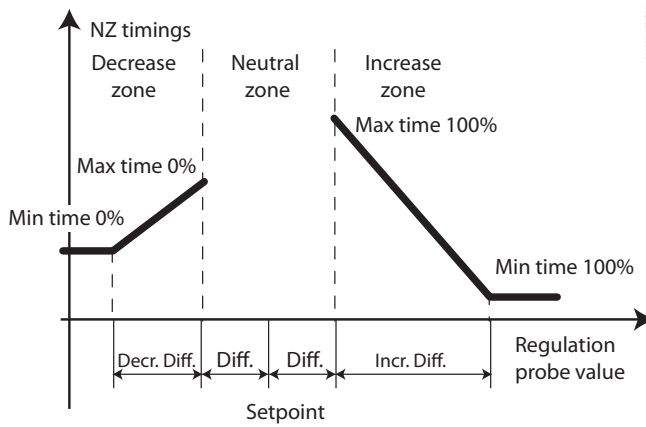

Fig. 5.e

User	Code	Description	Def	Min	Max	UOM
S	CRM	Maximum time in which the requested capacity reaches 100% with dead band control, line 1	60	CRn	999	s
S	CRMB	Maximum time in which the requested capacity reaches 100% with dead band control, line 2	60	CRnB	999	s
S	CRn	Minimum time in which the requested capacity reaches 100% with dead band control, line 1	60	0	CRM	s
S	CRnB	Minimum time in which the requested capacity reaches 100% with dead band control, line 2	60	0	CRMB	s
S	CRP	Minimum time in which the requested capacity reaches 0% with dead band control, line 1	10	0	CRQ	s
S	CRPB	Minimum time in which the requested capacity reaches 0% with dead band control, line 2	10	0	CRQB	s
S	CRQ	Maximum time in which the requested capacity reaches 0% with dead band control, line 1	60	CRP	999	s
S	CRQB	Maximum time in which the requested capacity reaches 0% with dead band control, line 2	60	CRPB	999	s
S	RDD	Decrease differential for dead band control, line 1	0.5	0.5	20	barg
S	RDD_T	Decrease differential for dead band control, line 1, expressed as a temperature	5	0	99.9	°C
S	Rddb	Decrease differential for dead band control, line 2	0.5	0.5	20	barg
S	Rddb_T	Decrease differential for dead band control, line 2, expressed as a temperature	5	0	99.9	°C
S	RDi	Increase differential for dead band control, line 1	0.5	0.5	20	barg
S	RDi_T	Increase differential for dead band control, line 1, expressed as a temperature	5	0	99.9	°C
S	RDiB	Increase differential for dead band control, line 2	0.5	0.5	20	barg
S	RDiB_T	Increase differential for dead band control, line 2, expressed as a temperature	5	0	99.9	°C

Tab. 5.f

In addition to the decrease and increase differentials RDD, RDD_T, RDDB, RDDB_T, RDi, RDi_T, RDiB, RDiB_T, four times need to be set, two for each zone CRM, CRMB, CRN, CRnB, CRP, CRPB, CRQ, CRQB, which represent the maximum and minimum time to reach a request equal to 0% or 100%, for decrease and increase respectively.

Tutorial: the decrease/increase times (minimum and maximum) represent the time required to transition from maximum to minimum capacity and vice-versa, and not the time between deactivation and activation of the individual device. For example, with four devices of equal capacity, an increase time of 180 s means that one device is activated every 45 s. In the case shown in the figure, the control request decreases/increases slowly upon exiting the dead band, while it decreases/increases quickly the further away from the dead band; in this way, the system response is faster when the conditions are less in equilibrium.

🔔 **Notice:** to use fixed times, set the maximum and minimum decrease/increase time to the same value. In this case, the control request decreases/increases constantly in accordance with the deactivation/activation differential.

5.2.3 Emergency control in the event of probe faults

In the event where the main control probes are not working, fixed control request values can be used, set using parameters DPc, DPcb, DFc.

User	Code	Description	Def	Min	Max	UOM
S	DPc	Capacity request during line 1 emergency operation	70	0	100	%
S	DPcb	Capacity request during line 2 emergency operation	70	0	100	%
S	DFc	Capacity request during condenser emergency operation	70	0	100	%

Tab. 5.g

5.3 Compressors

µRack can manage up to two suction lines with different types of compressors and capacity modulation devices, adopting the most common types of device rotation and controlling both the start-up modes and safety timings for each type compressor, as well as some accessory functions. The compressor functions are enabled and the corresponding parameters are set on the display or via Applica. These features and functions are described in detail below.

5.3.1 Permitted compressor configurations

µRack can manage different types of compressors, as well as a capacity modulation device on each suction line, which may differ according to the type of compressor:

Compressor	Modulation device
Reciprocating	0-10V inverter, Capacity steps (max 2)
Scroll	0-10V inverter, Digital Scroll™

Tab. 5.h

User	Code	Description	Def	Min	Max	UOM	
M	nC	Number of compressors, line 1	2	0	4	-	
M	nC2	Number of compressors, line 2 (0= line 2 not present)	0	0	2	-	
M	C1T	First compressor type, line 1 0= ON-OFF 1= inverter 2= Digital Scroll™	3= two steps 50-100 4= three steps 33-66-100	0	0	4	-
M	C1TB	First compressor type, line 2 – see C1T	0	0	4	-	
S	EC1	Enable compressor 1 line 1 (0: disabled; 1: enabled)	1	0	1	-	
S	EC2	Enable compressor 2 line 1 – see EC1	1	0	1	-	
S	EC3	Enable compressor 3 line 1 – see EC1	1	0	1	-	
S	EC4	Enable compressor 4 line 1 – see EC1	1	0	1	-	
S	EC1B	Enable compressor 1 line 2 – see EC1	1	0	1	-	
S	EC2B	Enable compressor 2 line 2 – see EC1	1	0	1	-	

Tab. 5.i

🔔 **Notice:** only one modulation device on each suction line

The controller can manage a maximum of six compressors, distributed as follows: on the first suction line, a maximum of four compressors, while on the second suction line the limit is two compressors.

All the possible combinations within the limits described above are valid. Example:

- 3 compressors on line 1 and 1 compressor on line 2
- 2 compressors on line 1 and 1 compressor on line 2
- 1 compressor on line 1 and 2 compressors on line 2

Once configured, each compressor can be disabled using parameters EC1, EC2, EC3, EC4, EC1B, EC2B, useful, for example, during maintenance.

🔔 **Notice:** verify that the controller has enough I/Os available for configuration

5.3.2 Rotation

µRack can manage three different types of device rotation, based on the setting of parameter Cro:

- FIFO rotation (First In First Out): the first device to start will also be the first to stop
- LIFO rotation (Last In First Out): the last device to start will be the first to stop
- Timed: the device with the lowest number of operating hours starts and the device with the highest number of operating hours stops

Example: FIFO rotation, four identical compressors without capacity control. The activation thresholds are 25, 50, 75 and 100 %.

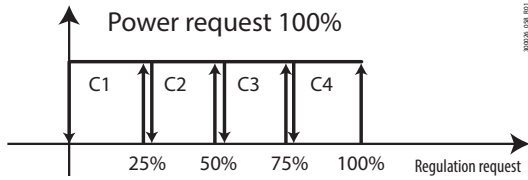

Fig. 5.f

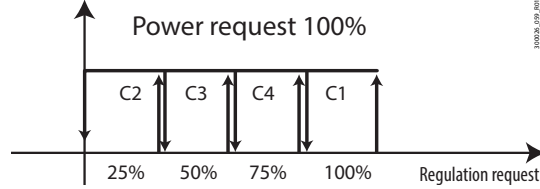

Fig. 5.g

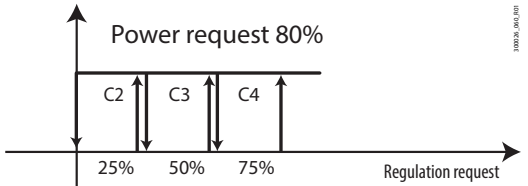

Fig. 5.h

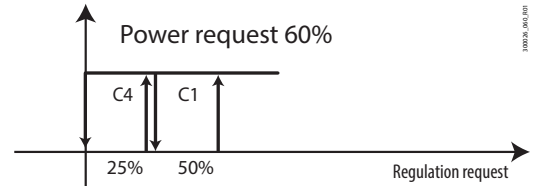

Fig. 5.i

User	Code	Description	Def	Min	Max	UOM
M	Cro	Compressor rotation type (0=FIFO, 1=LIFO, 2=Time)	0	0	2	-

Tab. 5.j

µRack also manages the delay times between the compressors switching on and off and between steps or compressors.

User	Code	Description	Def	Min	Max	UOM
M	CLD	Delay between OFF requests for steps/compressors on line 1	10	0	999	s
M	CLDB	Delay between OFF requests for steps/compressors on line 2	10	0	999	s
M	CLU	Delay between ON requests for steps/compressors on line 1	10	0	999	s
M	CLUB	Delay between ON requests for steps/compressors on line 2	10	0	999	s

Tab. 5.k

5.3.3 Rotation with modulation devices

µRack can manage compressor rotation even when there is a capacity modulation device (inverter or Digital Scroll™). The type of modulating device is selected using parameters C1T and C1TB. The modulating device is always the first to switch on and the last to switch off, regardless of the type of rotation, while the other devices switch on or off according to the type of rotation selected.

Notice: the compressor with the modulation device is always considered as the first compressor.

User	Code	Description	Def	Min	Max	UOM
M	CS1	Capacity of the first compressor, line 1	10	0	999	kW
M	CS2	Capacity of the second compressor, line 1	10	0	999	kW
M	CS3	Capacity of the third compressor, line 1	10	0	999	kW
M	CS4	Capacity of the fourth compressor, line 1	10	0	999	kW
M	CS1B	Capacity of the first compressor, line 2	10	0	999	kW
M	CS2B	Capacity of the second compressor, line 2	10	0	999	kW

Tab. 5.l

The trend in capacity supplied by the modulating device depends on the capacity of the corresponding compressor relative to the other compressors. There are three possible cases:

- compressors all of the same capacity and modulating device with a range of capacity modulation equal to or greater than the compressor capacity
- compressors all of the same capacity and modulating device with a range of capacity modulation less than the compressor capacity
- compressors of different capacities

In the first case, the modulating device can continuously cover the range of variation of the control request, while in the second case there will be some discontinuous variations. The behaviour in the third case is variable, and depending on the capacities involved, refer back to one of the two previous cases.

To configure the compressor capacity when controlled by an inverter, the minimum and maximum operating frequencies need to be set, corresponding to the minimum and maximum value of the analogue output and the rated capacity delivered at the rated frequency (50 Hz); in this way, µRack can calculate the capacity delivered by the inverter compressor and use this value for

control. Furthermore, for inverters the variation in capacity delivered can be limited by setting the increase and decrease times.

Example of range of capacity variation of the modulating device greater than the compressor capacity: 2 compressors without capacity control, 20 kW each, modulating device with variable capacity between 30 and 60 kW. The figure shows the trend for a control request that increases and then decreases continuously between 0 and 100%. It can be seen how the capacity delivered can exactly follow the capacity requested, except when the capacity is lower than the minimum capacity of the modulating device.

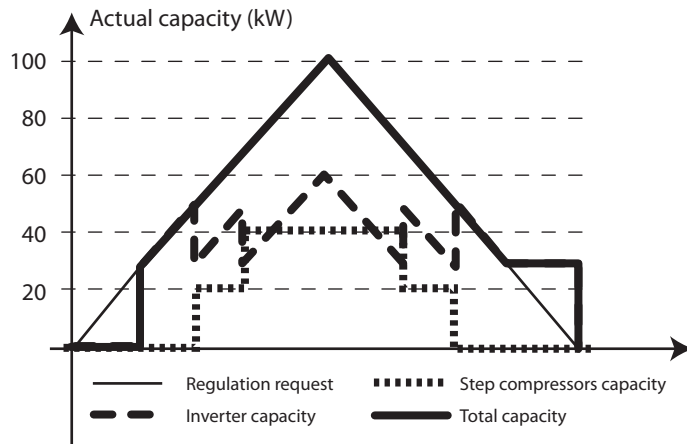

Fig. 5.j

User	Code	Description	Def	Min	Max	UOM
M	cMF	Maximum inverter control frequency, line 1	50	cnF	150	Hz
M	cnF	Minimum inverter control frequency, line 1	30	0	cMF	Hz
M	CRF	Rated inverter control frequency, line 1 (note: CS1 capacity refers to this frequency)	50	1	150	Hz
M	cMFB	Maximum inverter control frequency, line 2	50	cnFB	150	Hz
M	cnFB	Minimum inverter control frequency, line 2	30	0	cMFB	Hz
M	CRFB	Rated inverter control frequency, line 2 (note: CS1B capacity refers to this frequency)	50	1	150	Hz
M	iCD	Inverter deceleration time from 100% to 0% speed (line 1)	60	1	360	s
M	iCDB	Inverter deceleration time from 100% to 0% speed (line 2)	60	1	360	s
M	iCU	Inverter acceleration time from 0% to 100% speed (line 1)	100	1	360	s
M	iCUB	Inverter acceleration time from 0% to 100% speed (line 2)	100	1	360	s

Tab. 5.m

5.3.4 Safety times

µRack manages, for each compressor, the following common safety times:

- Minimum ON time C3: this is always considered, with the exception of when an alarm is activated that is configured to stop the compressor
- Minimum OFF time C2
- Minimum time between consecutive starts of C1

It is also possible to set a start delay time after a blackout c0, to avoid false starts.

User	Code	Description	Def	Min	Max	UOM
S	c0	Start delay after blackout	0	0	999	-
M	C1	Minimum time between two consecutive starts of each compressor on line 1	360	0	999	s
M	C2	Minimum OFF time for each compressor on line 1	120	0	999	s
M	C3	Minimum ON time for each compressor on line 1	10	0	999	s
M	C1B	Minimum time between two consecutive starts of each compressor on line 2	360	0	999	s
M	C2B	Minimum OFF time for each compressor on line 2	120	0	999	s
M	C3B	Minimum ON time for each compressor on line 2	10	0	999	s

Tab. 5.n

5.3.5 Digital Scroll™ compressors

µRack can use a Digital Scroll™ compressor (one on each line) as a modulating device for the suction lines. This type of compressor features specific operation and control by µRack, as described below.

The corresponding parameters can only be used using specific configurations available in Applica. Capacity modulation is obtained by opening/closing a valve with PWM modulating signal; when the valve is ON, the compressor delivers minimum capacity, while when the valve is OFF the compressor delivers maximum capacity. In the description and figures below, ON and OFF refer to the compressor status, while operation of the valve is the exact opposite:

Notice:

- the minimum capacity that can be delivered by the Digital Scroll™ compressors is $\text{Min. ON time} / \text{Max cycle time} = 2/20 = 10\%$;
- in the event of high pressure prevention by activating/deactivating the devices, the Digital Scroll™ compressor delivers the minimum capacity.

Start-up procedure

µRack manages the start-up procedure for Digital Scroll™ compressors, which is represented in the figure:

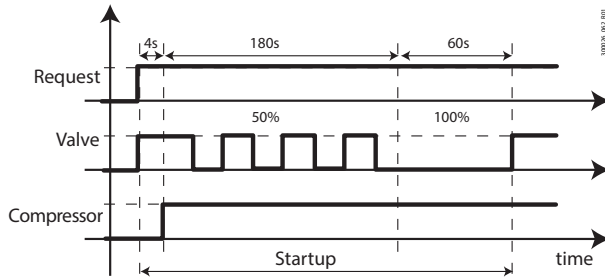

Fig. 5.k

Digital Scroll™						
User	Code	Description	Def.	Min.	Max.	UOM
M	DigitalScroll_1.DefVlvCycleT	Default valve cycle time – Digital Scroll™ line 1	12	0	65535	s
M	DigitalScroll_1.DefVlvOFF_T	Default valve OFF time – Digital Scroll™ line 1	10	0	65535	s
M	DigitalScroll_1.DefVlvON_T	Default valve ON time – Digital Scroll™ line 1	2	0	65535	s
M	DigitalScroll_1.MaxVlvCycleT	Maximum valve cycle time – Digital Scroll™ line 1	20	0	65535	s
M	DigitalScroll_1.MaxVlvOFF_T	Maximum valve OFF time – Digital Scroll™ line 1	20	0	65535	s
M	DigitalScroll_1.MaxVlvON_T	Maximum valve ON time – Digital Scroll™ line 1	18	0	65535	s
M	DigitalScroll_1.MinVlvCycleT	Minimum valve cycle time – Digital Scroll™ line 1	12	0	65535	s
M	DigitalScroll_1.MinVlvOFF_T	Minimum valve OFF time – Digital Scroll™ line 1	2	0	65535	s
M	DigitalScroll_1.MinVlvON_T	Minimum valve ON time – Digital Scroll™ line 1	0	0	65535	s
M	DigitalScroll_1.StartUpPwr1	Starting capacity – stage 1 – Digital Scroll™ line 1	0	0	100	%
M	DigitalScroll_1.StartUpPwr2	Starting capacity – stage 2 – Digital Scroll™ line 1	50	0	100	%
M	DigitalScroll_1.StartUpPwr3	Starting capacity – stage 3 – Digital Scroll™ line 1	100	0	100	%
M	DigitalScroll_1.StartUpT1	Starting time – stage 1 – Digital Scroll™ line 1	4	0	65535	s
M	DigitalScroll_1.StartUpT2	Starting time – stage 2 – Digital Scroll™ line 1	180	0	65535	s
M	DigitalScroll_1.StartUpT3	Starting time – stage 3 – Digital Scroll™ line 1	60	0	65535	s
M	DigitalScroll_2.DefVlvCycleT	Default valve cycle time – Digital Scroll™ line 2	12	0	65535	s
M	DigitalScroll_2.DefVlvOFF_T	Default valve OFF time – Digital Scroll™ line 2	10	0	65535	s
M	DigitalScroll_2.DefVlvON_T	Default valve ON time – Digital Scroll™ line 2	2	0	65535	s
M	DigitalScroll_2.MaxVlvCycleT	Maximum valve cycle time – Digital Scroll™ line 2	20	0	65535	s
M	DigitalScroll_2.MaxVlvOFF_T	Maximum valve OFF time – Digital Scroll™ line 2	20	0	65535	s
M	DigitalScroll_2.MaxVlvON_T	Maximum valve ON time – Digital Scroll™ line 2	18	0	65535	s
M	DigitalScroll_2.MinVlvCycleT	Minimum valve cycle time – Digital Scroll™ line 2	12	0	65535	s
M	DigitalScroll_2.MinVlvOFF_T	Minimum valve OFF time – Digital Scroll™ line 2	2	0	65535	s
M	DigitalScroll_2.MinVlvON_T	Minimum valve ON time – Digital Scroll™ line 2	0	0	65535	s
M	DigitalScroll_2.StartUpPwr1	Starting capacity – stage 1 – Digital Scroll™ line 2	0	0	100	%
M	DigitalScroll_2.StartUpPwr2	Starting capacity – stage 2 – Digital Scroll™ line 2	50	0	100	%
M	DigitalScroll_2.StartUpPwr3	Starting capacity – stage 3 – Digital Scroll™ line 2	100	0	100	%
M	DigitalScroll_2.StartUpT1	Starting time – stage 1 – Digital Scroll™ line 2	4	0	65535	s
M	DigitalScroll_2.StartUpT2	Starting time – stage 2 – Digital Scroll™ line 2	180	0	65535	s
M	DigitalScroll_2.StartUpT3	Starting time – stage 3 – Digital Scroll™ line 2	60	0	65535	s

Tab. 5.o

Data provided by the compressor manufacturer	minimum ON time 2 s maximum cycle time 20 s optimal cycle time 12 s
--	---

There are three stages:

1. equalisation: the PWM valve is activated for 4 s, to bring the compressor to minimum capacity;
2. activation of the compressor at 50% capacity for 3 minutes;
3. operation at 100% for 1 minute.

During the start-up procedure, the control request is ignored, and only at the end of the procedure does the capacity delivered begin to reflect the request. If the request is cancelled during start-up, the compressor switches off at the end of the procedure, and therefore the minimum ON time for this type of compressor is fixed at 244 s. The start-up procedure is completed when the compressor starts the first time, while it is disabled at subsequent restarts, unless the compressor has been off for a settable time. After this time has elapsed, the procedure is repeated at next start-up.

Notice: the Digital Scroll™ compressor safety times are defined by the manufacturer, and are:

- Minimum ON time; 244 s (start-up procedure)
- Minimum OFF time: 180 s
- Minimum time between restarts: 360 s

Caution: For Digital Scroll™ modulating compressors, the unloader output must be configured on an SSR output, or alternatively external SSR relays with an input voltage compatible with the 0-10 V outputs Y1 and Y2 can be connected. See “Input and output configuration”.

5.3.6 Low superheat protection

µRack can preserve correct compressor operation by promptly recognising liquid return from the system and implementing preventive protection actions.

The protection algorithm features two activation thresholds that can be set in terms of superheat value, i.e. the difference between the suction temperature measured by the corresponding temperature sensor, and the converted saturated temperature read by the pressure sensor. The protection acts independently on the two suction lines and is always active.

User	Code	Description	Def	Min	Max	UOM
S	LshP	Safety threshold for superheat protection	6	LshA	20	°K
S	LshA	Emergency threshold for superheat protection	2	-20	LshP	°K
S	Lshd	Emergency delay for superheat protection, line 1	5	0	60	s
S	Lhdb	Emergency delay for superheat protection, line 2	5	0	60	s
M	AtS	Type of low superheat alarm reset, line 1 (0= automatic; 1= manual; 2= semi-automatic)	1	0	2	-
M	AtSb	Type of low superheat alarm reset, line 2 (0= automatic; 1= manual; 2= semi-automatic)	1	0	2	-
S	LshC	Emergency control (duty cycle) activation time in a fixed period of 10 minutes	4	0	10	min

Tab. 5.p

The first safety threshold (LshP) guarantees limited operation, safeguarding the modulating compressor by switching it OFF, always in compliance with the safety times. Safety mode is activated after a delay that can be set using parameter LSP (LSPb for line 2) and is deactivated as soon as the line suction superheat exceeds the threshold value (LshP) + 1K differential.

Notice: the modulating compressor that is switched off is replaced by another in rotation (see chap. 5.2.2) so as to satisfy the control request. For the modulating compressor to be restarted, there needs to be a higher capacity request than the current capacity delivered, otherwise another compressor needs to first be stopped by the controller and then, when the capacity request next increases, this will be the first to start due to the normal priority.

Emergency mode is activated when the superheat value falls below the threshold (LshA) for a time greater than the set delay (Lshd). Alarm LSH or LS2 is activated (see details in paragraph 8.3), stopping control of the line in question during this dangerous situation. Alarm reset can be configured as automatic, manual or semi-automatic, as set using parameters AtS and AtSb.

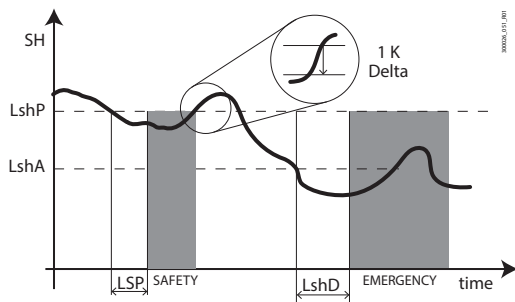

Fig. 5.l

An intermittent operating mode can be configured for the time the alarms remain active so as to ensure service continuity, pending a thorough check of the system to identify the cause of the malfunction. This intermittent mode can be configured using parameter LshC, parameter which expresses the time in which the capacity set for DPc is requested (DPcb for line 2) in a 10-minute period, as shown in the figure.

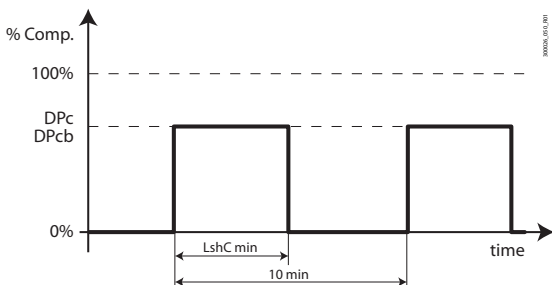

Fig. 5.m

Notice: the function is always active with a delay that can be set separately for each control line; to disable the protection, set parameters LshA and LshP to -20.0 K

5.3.7 High pressure prevention

μRack can manage the high condensing pressure prevention function, which acts by overriding the compressors and fans. When the high condensing pressure (HPv) prevent alarm is triggered, the function starts all the fans at maximum speed and stops all the compressors, except for the minimum capacity step, without waiting for the control times yet respecting the compressor protection times.

Minimum capacity step refers to one compressor for compressors without unloader and without modulating devices, or the minimum capacity step for compressors with unloader (e.g. 25%), or the minimum capacity that the modulating device can deliver for inverter or Digital Scroll™ compressors and compressors with stage modulation.

In addition to the activation threshold (Pvt), which is always absolute, a delay can be set between deactivation of one compressor and the next (cLdP), except for the minimum capacity step set.

Furthermore, the evaluation time (PVd) can also be set; this is the period of time in which five prevention activations are allowed. If there are more than five activations in the set time, the prevent alarm reset becomes manual.

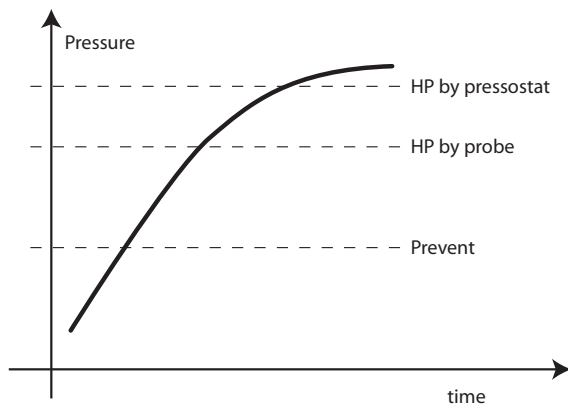

Fig. 5.n

The protection parameters are summarised in the following table:

User	Code	Description	Def	Min	Max	UOM
M	cLdP	High discharge pressure prevention, OFF delay between compressors	30	0	999	s
S	LSP	Safety delay for superheat protection, line 1	5	0	60	s
S	LSPb	Safety delay for superheat protection, line 2	5	0	60	s
M	Pvd	High discharge pressure prevention, evaluation time	5	0	999	min
M	Pvt	High discharge temperature prevention, threshold	18/ 261	0	45/ 652.5	barg/ psig
M	Pvt_T	High discharge temperature prevention, threshold expressed as a temperature	55/131	0732	1507302	°C/°F

Tab. 5.q

5.3.8 Oil recovery

μRack can optimise recovery of the oil that during normal operation exits the compressor crankcase.

In particular, when refrigerant flow-rate control technologies are used, when the gas speed returning to the compressor is low for an extended time, this is not sufficient to carry the oil that accumulates in the system piping.

The controller continuously checks the status of the active compressors to start the recovery procedure if the percentage of active capacity is lower than a threshold, set for parameter orn (ornb for line 2). The procedure is divided into four different phases:

Phase	Description
1 - Delay	Analysis by the controller: if compressor capacity remains below the threshold beyond the delay time orU (orUB), the active oil recovery phase begins. No changes to normal control during this phase
2 - Pause	The compressors on the line are switched off for the time set by parameter orP (orPb), respecting the safety times
3 - Recovery	The compressors are all started for the time set by parameter orF (orFb), at maximum capacity for capacity-control or modulating devices. Any of the safety procedures may be activated to interrupt the recovery in progress.
4 - Stabilisation	Normal control resumes, and due probable excess capacity delivered in the previous phase, the controller may stop the compressors; to avoid control errors, complete shutdown is avoided, keeping the unit at the minimum deliverable capacity for the time set by parameter orA (orAb).

Tab. 5.r

The behaviour described above can be represented as shown in the chart:

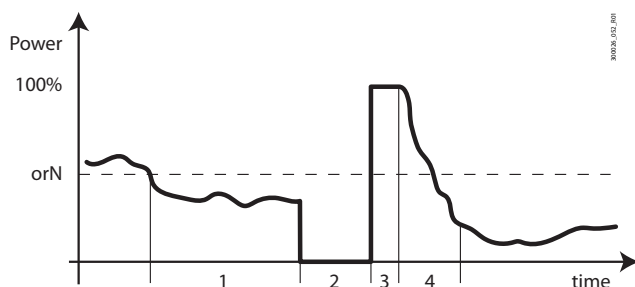

Fig. 5.0

The parameters relating to oil recovery are listed here:

User	Code	Description	Def	Min	Max	UOM
S	orn	Minimum compressor capacity for oil recovery – line 1	40	0	100	%
S	ornb	Minimum compressor capacity for oil recovery – line 2	40	0	100	%
S	orU	Delay time for oil recovery – line 1	60	0	999	min
S	orUb	Delay time for oil recovery – line 2	60	0	999	min
S	orP	Pause time for oil recovery - line 1	600	0	9999	s
S	orPb	Pause time for oil recovery - line 2	600	0	9999	s
S	orF	Force ON time for oil recovery - line 1	300	0	9999	s
S	orFb	Force ON time for oil recovery - line 2	300	0	9999	s
S	orA	Stabilisation time for oil recovery – line 1	600	0	9999	s
S	orAb	Stabilisation time for oil recovery – line 2	600	0	9999	s

Tab. 5.s

5.3.9 Pump down

When there is a request to switch off the compressors, μ Rack manages the pump down procedure, so as to empty refrigerant gas from the evaporators.

User	Code	Description	Def	Min	Max	UOM
S	CPL	End pump down threshold for line 1	1/ 14.5	-1/ -14.5	SP	barg/ psig
S	CPLB	End pump down threshold for line 2	1/ 14.5	-1/ -14.5	SPB	barg/ psig
S	CPT	Maximum pump down duration, line 1 (0 = pump down disabled)	0	0	60	min
S	CPTB	Maximum pump down duration, line 2 (0 = pump down disabled)	0	0	60	min

Tab. 5.t

During pump down, the minimum capacity step of the compressors on the line remains active until the suction pressure reaches the threshold CPL (CPLB for line 2) or when the maximum duration CPT is reached (CPTB for line 2), depending on which condition occurs first. If the pump down duration is set to zero, the procedure is disabled.

5.4 Fans

μ Rack can manage a common condensing line with the possibility to directly control up to four fans, set using parameter nF, or a speed modulation device (inverter or phase control).

Notice: if a speed modulation device is used and there are multiple fans in parallel, the control signal is the same for all fans; if separate alarms are configured, the alarm relating to fan 1 is the only one that can stop control, the others are signal only.

The controller guarantees uniform wear on the components by implementing the most common types of rotation on the devices, and protects them by controlling both the starting modes and some additional functions.

User	Code	Description	Def	Min	Max	UOM
M	IFL1	Type of fan 1 (0= ON/OFF; 1=Inverter)	0	0	1	-
S	FRo	Fan rotation type (0= FIFO, 1= LIFO)	0	0	1	-
M	nF	Number of condenser fans	2	0	4	-
S	EF1	Enable fan 1 (0= disabled; 1= enabled)	1	0	1	-
S	EF2	Enable fan 2 – see EF1	1	0	1	-
S	EF3	Enable fan 3 – see EF1	1	0	1	-
S	EF4	Enable fan 4 – see EF1	1	0	1	-

Tab. 5.u

Once configured, each fan can be disabled using parameters EF1, EF2, EF3, EC4, useful, for example, during maintenance.

5.4.1 Control

µRack manages - as described in par. 5.1 - different types of proportional band or dead band control, using the values read by the pressure sensor, either directly or by converting these into saturated temperature. For details on the type of control, see par. 5.1; the features relating to the fans only are described below.

User	Code	Description	Def	Min	Max	UOM
S	DFc	Capacity request during condenser emergency operation	70	0	100	%
S	FTI	Integral time for P+I condenser fan control	600	0	999	s
S	FRC	Force off threshold for dead band fan control	-1/ -14.5	-1/ -14.5	20/290	barg/psig
S	FRC_T	Force off threshold for dead band fan control, expressed as a temperature	-50/-58	-99.9/ -147.8	99.9/ 211.8	°C/°F
S	FRM	Maximum time in which the requested capacity reaches 100% with dead band fan control	60	FRn	999	s
S	FRn	Minimum time in which the requested capacity reaches 100% with dead band fan control	20	0	FRM	s
S	FRP	Minimum time in which the requested capacity reaches 0% with dead band fan control	10	0	FRQ	s
S	FRQ	Maximum time in which the requested capacity reaches 0% with dead band fan control	60	FRP	999	s
S	FrT	Fan control type (0= P+; 1= dead band)	1	0	1	-
S	RDF	Condenser fan control differential	3/ 43.5	0	20/290	Δbarg / Δpsig
S	RDF_T	Condenser fan control differential, expressed as a temperature	15/ 27	0	99.9/ 179.8	Δ°C / Δ°F
S	RDFD	Decrease differential for condenser fan dead band control	0.5/ 7.2	0.5/ 7.2	20/ 290	Δbarg / Δpsig
S	RDFD_T	Decrease differential for condenser fan dead band control, expressed as a temperature	0.5/ 32.9	-99.9/ 179.8	99.9/ 179.8	Δ°C / Δ°F
S	RDFi	Increase differential for condenser fan dead band control	0.5/ 7.2	0.5/ 7.2	20/ 290	Δbarg / Δpsig
S	RDFI_T	Increase differential for condenser fan dead band control, expressed as a temperature	0.5/ 0.9	-99.9/ -179.8	99.9/ 179.8	Δ°C / Δ°F
U	STF	Condenser fan control set point	15.5/ 224.8	STFL	STFH	barg/ psig
U	STFT	Condenser fan control set point, expressed as a temperature	15.5/ 59.5	STFL_T	STFH_T	°C/°F
M	STFH	Condenser fan control set point maximum limit	25/ 362.5	STFL	/US	barg/ psig
M	STFH_T	Condenser fan control set point maximum limit, expressed as a temperature	55.5/ 77	STFL_T	99.9/ 211.8	°C/°F
M	STFL	Condenser fan control set point minimum limit	1/ 14.5	0	STFH	barg/ psig
M	STFL_T	Condenser fan control set point minimum limit, expressed as a temperature	1/ 33.8	0/ 32	STFH_T	°C/°F

Tab. 5.v

Fan operation linked to the compressors

Operation of the fans can be linked to the operation of the compressors by setting a parameter F31, in which case the fans are activated only if at least one compressor is ON

User	Code	Description	Def	Min	Max	UOM
S	F31	Fans ON with compressors ON 0= fans ON also with compressor OFF 1= fans ON when at least one compressor is ON	0	0	1	-

Tab. 5.w

Fan operation with modulating device

If the fans are controlled by a modulating device, the meaning of the parameters that associate the minimum and maximum values of the device's modulating output and the minimum and maximum capacity of the modulating device is illustrated in the following examples.

User	Code	Description	Def	Min	Max	UOM
M	FHC	Condenser fan inverter maximum speed	100	FLC	100	%
M	FLC	Condenser fan inverter minimum speed	20	0	FHC	%
S	FLo	Minimum condenser fan inverter output	40	0	100	%

Tab. 5.x

Example 1: minimum modulating output value 0V (0V), maximum value 100% (10V), minimum modulating device capacity 0%, maximum value 100%.

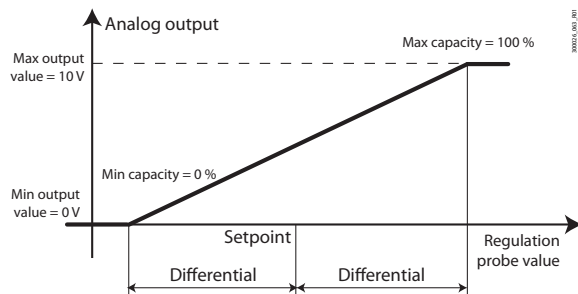

Fig. 5.p

Example 2: minimum modulating output value 0V, maximum value 10V, minimum modulating device capacity 60%, maximum value 100%.

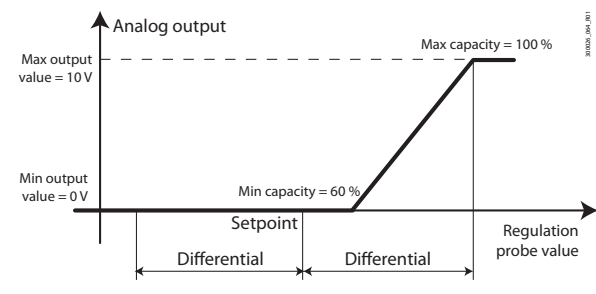

Fig. 5.q

Example 3: minimum modulating output value 2 V, maximum value 10 V, minimum modulating device capacity 60 %, maximum value 100 %.

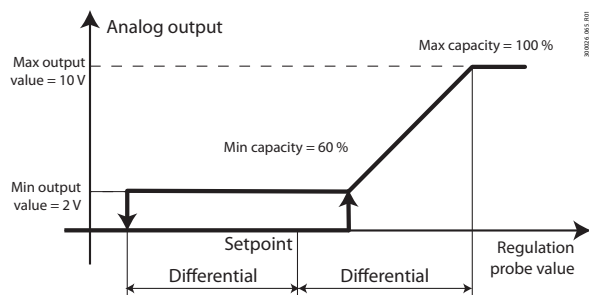

Fig. 5.r

The minimum and maximum values of the output are linked to the analogue output configured for the output signal, each channel has a minimum parameter Ao1n, Ao2n and a maximum parameter Ao1M, Ao2M that can be set as necessary.

User	Code	Description	Def	Min	Max	UOM
S	Ao1M	Maximum output value for Y1	10	Ao1n	10	-
S	Ao1n	Minimum output value for Y1	0	0	Ao1M	-
S	Ao2M	Maximum output value for Y2	10	Ao2n	10	-
S	Ao2n	Minimum output value for Y2	0	0	Ao2M	-

Tab. 5.y

The 0-10V signal can be delayed by setting the corresponding parameters iFU and IGd, so as to avoid abrupt changes in capacity due to system transients. µRack allows the increase or decrease control signal times to be set separately.

The delay time refers to a sudden variation in control request from a starting state of 0% (0 V) to 100% (10 V); in this case, the output signal will gradually increase and reach the value of 100% (10 V) only after the time set using parameter iFU; the same applies to a decrease and the corresponding parameter IFd.

User	Code	Description	Def	Min	Max	UOM
M	iFU	Condenser fan inverter acceleration time from 0% to 100% speed	2	0	360	s
M	IFd	Condenser fan inverter deceleration time from 100% to 0% speed	10	0	360	s

Tab. 5.z

5.4.2 Rotation

µRack manages fan rotation in the same way as described for the compressors, and therefore, parameter Fro can be set to enable LIFO, FIFO and timed rotation. Furthermore, a modulating device can be managed, set using parameter IFL1.

The substantial difference compared to the compressors involves the possibility of managing different sizes and obviously capacity control, which are not available for the fans. Furthermore, µRack can specifically manage fans driven by inverter. In fact, there can be only one modulating fan, or several fans can be controlled in parallel (all at the same speed) without rotation. Finally, two delay can also be set for the fans, between ON and OFF in rotation, using parameters FLD and FLU.

User	Code	Description	Def	Min	Max	UOM
S	Fro	Fan rotation type (0= FIFO, 1= LIFO)	0	0	1	-
M	IFL1	Type of fan 1 (0= ON/OFF; 1= Inverter)	0	0	1	-
S	FLD	Switch OFF delay between fans with rotation OFF request	2	0	999	s
S	FLU	Switch ON delay between fans with rotation ON request	2	0	999	s

Tab. 5.aa

5.4.3 Fan speed up

µRack can manage the speed up function, used to overcome the initial inertia of the fans.

If speed up is enabled (parameter FSU), a start time can be set in which the fan speed is forced to 100%. If the outside temperature probe is used, moreover, a threshold FSE can be set (with a fixed 5°C reset differential) below which speed up is disabled, so as to not drastically lower the condensing pressure at start-up.

User	Code	Description	Def	Min	Max	UOM
S	FSU	Enable modulating fan speed up 0= disabled; 1= enabled	0	0	1	-
S	FSt	Speed up time when starting the fan	5	0	60	s
S	FSE	Minimum outside temperature threshold for disabling modulating fan speed up	0/ 32	-50/ -58	50/ 122	°C/ °F

Tab. 5.ab

5.5 Energy saving

µRack can activate energy saving functions by modifying the suction and condensing stage set points.

Two different offsets can be applied to both the suction and condensing stage set points, which can be activated by:

- Digital input
- Time band

These two offsets can be used, for example, for the closing period and for winter.

When the digital input set via parameter DiSC is activated, the values set for parameters SPE, SPEb and Cto are added to the two suction line and condensing stage set points. Similarly, inside the daily time band set using parameters SSh, SSn and SEh, SEh, the offsets SPo, SPob and CtE are added to the set points. The two effects are independent and can superimpose each other, as shown in the figure.

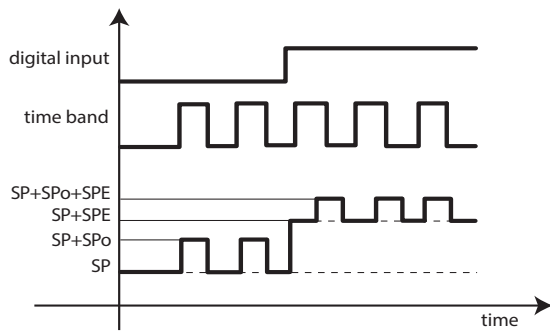

Fig. 5.s

In addition to set point compensation via digital input and time bands, two further energy saving functions can be used: floating suction and condensing set points.

User	Code	Description	Def	Min	Max	UOM
S	CtE	Fan control set point offset for compensation by time band	0	-9.9/ -143.5	99/ 143.5	$\Delta\text{bar}/$ Δpsig
S	CtE_T	Fan control set point offset for compensation by time band, expressed as a temperature	0	-99.9/ -179.8	99/ 179.8	$\Delta^\circ\text{C}/ \Delta^\circ\text{F}$
S	Cto	Fan control set point offset for compensation by digital input	0	-9.9/ -143.5	99/ 143.5	$\Delta\text{bar}/$ Δpsig
S	Cto_T	Fan control set point offset for compensation by digital input, expressed as a temperature	0	-99.9/ -179.8	99/ 179.8	$\Delta^\circ\text{C}/ \Delta^\circ\text{F}$
S	SPE	Control set point offset for time bands, line 1	0	-9.9/ -143.5	99/ 143.5	$\Delta\text{bar}/$ Δpsig
S	SPE_T	Control set point offset for time bands, line 1, expressed as a temperature	0	-99.9/ -179.8	99/ 179.8	$\Delta^\circ\text{C}/ \Delta^\circ\text{F}$
S	SPEb	Control set point offset for time bands, line 2	0	-9.9/ -143.5	99/ 143.5	$\Delta\text{bar}/$ Δpsig
S	SPEb_T	Control set point offset for time bands, line 2, expressed as a temperature	0	-99.9/ -179.8	99/ 179.8	$\Delta^\circ\text{C}/ \Delta^\circ\text{F}$
S	SPo	Control set point offset for compensation by digital input, line 1	0	-9.9/ -143.5	9.9/ 143.5	$\Delta\text{bar}/$ Δpsig
S	SPo_T	Control set point offset for compensation by digital input, line 1, expressed as a temperature	0	-99.9/ -179.8	99.9/ 179.8	$\Delta^\circ\text{C}/ \Delta^\circ\text{F}$
S	SPob	Control set point offset for compensation by digital input, line 2	0	-9.9/ -143.5	9.9/ 143.5	$\Delta\text{bar}/$ Δpsig
S	SPob_T	Control set point offset for compensation by digital input, line 2	0	-99.9/ -179.8	99.9/ 179.8	$\Delta^\circ\text{C}/ \Delta^\circ\text{F}$
U	SEh	End time band, hours	7	0	23	h
U	SEM	End time band, minutes	30	0	59	min
U	SSh	Start time band, hours	17	0	23	h
U	SSM	Start time band, minutes	30	0	59	min

Tab. 5.ac

5.5.1 Floating suction set point

For the suction line, the floating set point function uses a specific algorithm managed by a CAREL supervisor (boss family). If the floating suction set point is enabled using parameter FLE (FLEb for line 2), the suction set point set by the user is adjusted by the supervisor, between a minimum and a maximum that can be set using parameters FLL (FLLb) and FLH (FLHb). Operation is illustrated in the following figure:

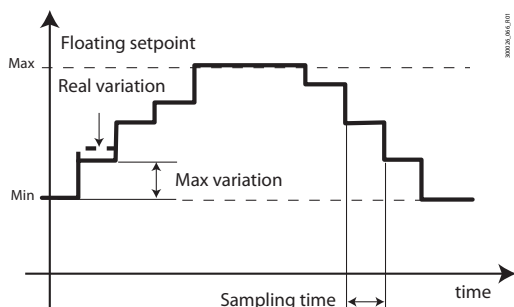

Fig. 5.t

The set point is calculated by the supervisor and acquired by the μ Rack controller at time intervals set by parameter FLt (FLtb). The maximum allowed variation for the set point in each sampling period can be set, and if the acquired value differs from the previous one by more than the maximum variation allowed, the variation is limited to the maximum. If the supervisor is disconnected, after 10 minutes (fixed) the μ Rack controller begins to decrease the set point with variations equal to the maximum variation allowed for each sampling period, until reaching the minimum floating suction set point allowed.

User	Code	Description	Def	Min	Max	UOM
S	FLE	Enable floating suction set point, line 1 (0= disabled; 1= enabled)	0	0	1	-
S	FLH	Maximum floating suction set point, line 1	0	FLL	SPH	barg/ psig
S	FLL	Minimum floating suction set point, line 1	0	SPL	FLH	barg/ psig
S	FLM	Floating suction set point maximum variation, line 1	1/ 14.5	0	9.9/ 143.5	Δ bar/ Δ psig
S	FLt	Floating suction set point sampling time, line 1	0	0	999	min
S	FLEb	Enabling floating suction set point, line 2 – see FLE	0	0	1	-
S	FLHb	Maximum floating suction set point, line 2	0	FLLb	SPHB	barg/ psig
S	FLLb	Minimum floating suction set point, line 2	0	SPLB	FLHb	barg/ psig
S	FLMb	Floating suction set point maximum variation, line 2	1/ 14.5	0	9.9/ 143.5	Δ bar/ Δ psig
S	FLtb	Floating suction set point sampling time, line 2	0	0	999	min
S	FLH_T	Maximum floating suction set point, line 1, expressed as a temperature	0/ 32	FLL_T	SPH_T	$^{\circ}$ C/ $^{\circ}$ F
S	FLHb_T	Maximum floating suction set point, line 2, expressed as a temperature	0/ 32	FLLb_T	SPHB_T	$^{\circ}$ C/ $^{\circ}$ F
S	FLL_T	Minimum floating suction set point, line 1, expressed as a temperature	0/ 32	SPL_T	FLH_T	$^{\circ}$ C/ $^{\circ}$ F
S	FLLb_T	Minimum floating suction set point, line 2, expressed as a temperature	0/ 32	SPLb_T	FLHb_T	$^{\circ}$ C/ $^{\circ}$ F

Tab. 5.ad

Notice: if set point compensation is active by scheduler or digital input, the offset is added to the minimum and maximum limits for the floating set point.

5.5.2 Floating condensing set point

For the condensing line, the floating set point function is based on the outside temperature read by the probe connected to the µRack controller. If the floating condensing set point is enabled using parameter FLcE, the set point is obtained by adding a set constant (FLcd) to the outside temperature and limiting the resulting value between the minimum and maximum values STFL_T and STFH_T, as illustrated in the figure:

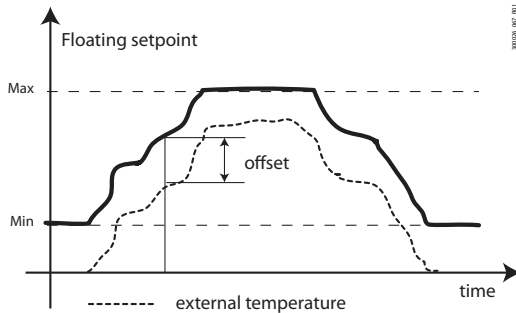

Fig. 5.u

User	Code	Description	Def	Min	Max	UOM
S	FLcE	Enable floating condensing set point (0= disabled; 1= enabled)	0	0	1	-
S	FLcd	Temperature offset for floating condensing set point	10/ 18	-40/ -72	150/ 270	Δ°C/ Δ°F
M	STFH	Condenser fan control set point maximum limit	25/ 362.5	STFL	/US	barg/ psig
M	STFL	Condenser fan control set point minimum limit	1/ 14.5	0	STFH	barg/ psig

Tab. 5.ae

Notice: if set point compensation is active by scheduler, digital input or supervisor, the offset is added to the minimum and maximum limits for the floating set point.

5.6 Manual device management

Operation of the individual actuators fitted on the unit can be switched from automatic to manual. For digital outputs, the options are ON or OFF, while analogue outputs can be set from 0 to 100%; the default values are all Auto.

User	Code	Description	Def	Min	Max	UOM
S	Mc1	Manual mode, compressor 1 line 1 ON/OFF compressor (0= automatic; 1= OFF; 2= OFF) Compressor with 0-50-100% steps (0= automatic; 1= OFF; 2= 50%; 3= 100%). Compressor with 0-33-66-100% steps (0= automatic; 1= OFF; 2= 33%; 3= 66%; 4= 100%) Compressor with inverter or Digital Scroll™ (0= automatic; 1= OFF; 2= 2%, ..., 100= 100%)	0	0	100	-
S	Mc2	Manual mode, compressor 2 line 1 (0= automatic, 1= OFF, 2= ON)	0	0	2	-
S	Mc3	Manual mode, compressor 3 line 1 – see Mc2	0	0	2	-
S	Mc4	Manual mode, compressor 4 line 1 – see Mc2	0	0	2	-
S	Mc1b	Manual mode, compressor 1 line 2 – see Mc1	0	0	100	-
S	Mc2b	Manual mode, compressor 2 line 2 – see Mc2	0	0	2	-
S	MEF	Manual mode, fan 1: ON/OFF fan 0= automatic; 1= OFF; 2= ON) Fan with inverter (0= automatic; 1= OFF; 2= 2%, ..., 100= 100%)	0	0	101	-
S	MEF2	Manual mode, fan 2 (0= automatic; 1= OFF; 2= ON)	0	0	2	-
S	MEF3	Manual mode, fan 3 (0= automatic; 1= OFF; 2= ON)	0	0	2	-
S	MEF4	Manual mode, fan 4 (0= automatic; 1= OFF; 2= ON)	0	0	2	-

Tab. 5.af

These operations bypass temperature control, but not the alarm thresholds set to protect unit safety; in general, these operations are used to test the individual actuators during installation.

Parameters Mc1, Mc1b and MEF parameters that override the status of modulating devices or devices with modulation steps have a precise meaning that is based on the unit configuration:

Devices	Modulation	Parameter value description
Compressors	ON/OFF	0= AUTO, 1= OFF, 2= ON
	Unloaders	0= AUTO, 1= OFF, 2= STEP 1, 3= STEP 2, 4= STEP 3
	0-10 V inverter or Digital Scroll™	0= AUTO, 1= OFF, 2...100 -> 2% ...100%
Condenser fans	ON/OFF	0= AUTO, 1= OFF, 2= ON
	0-10 V inverter	0= AUTO, 1= OFF, 2...100 -> 2% ...100%

Tab. 5.ag

Manual operation of the devices is described below:

Devices	Notes
Compressors	Safety times taken into account All compressor alarms are enabled
Condenser fans	Speed-up disabled

Tab. 5.ah

Manual device operation is notified on the display by the spanner icon flashing in red.

5.7 Settings

5.7.1 Clock

µRack is equipped with an internal clock that keeps the time and date for all of the corresponding functions (see chap. 8 for details on the hardware).

The current date and time can be set, and the day of the week can be displayed corresponding to the date set via Applica or supervisor. The transition to summer/winter time is managed based on the time zone set using the commissioning tool (see chap. 3 for details on commissioning).

If the clock card is not working, an alarm is generated and the associated functions are no longer available; the alarms and log stored in the controller's memory will refer to the default date 1/1/1970.

User	Code	Description	Def	Min	Max	UOM
U	d__	Date/time setting from supervisor, day	1	1	31	-
U	h__	Date/time setting from supervisor, hours	0	0	23	h
U	M__	Date/time setting from supervisor, month	1	1	12	-
U	m__	Date/time setting from supervisor, minutes	0	0	59	min
U	y__	Date/time setting from supervisor, year	20	20	99	-

5.8 Default value management

The default values shown in this manual for each parameter and that can be modified by the user are permanently stored in the controller. The default values can be restored using a dedicated procedure on the seven-segment display or by loading the "Default" configuration on Applica Desktop or smartphone.

Procedure with seven segment display

1. Power off the controller
2. Press PRG on the display
3. Power on the controller while still holding PRG
4. Release PRG when the message "rSC" is shown on the display

Procedure with Applica (smartphone or PC)

1. Open the Applica app on smartphone or PC
2. Connect to the device via NFC or Bluetooth (smartphone) or using the CVSTDUMOR0 converter (PC)
3. Enter the credentials provided
4. Select the "parameter list" item from the menu and select parameter rSC
5. Apply the value TRUE

Alternatively, select the "Configurations" item from the menu, select the "Default" item and apply the configuration values to the connected controller.

5.9 Generic functions

µRack can exploit unused inputs and outputs to configure one or more generic functions. Each generic function can be enabled/disabled from the APPLICA app or SPARK configuration software.

The following can be activated:

- 1 generic function with On/Off output;
- 1 generic function with modulating output;
- 1 generic alarm function (set as warning or serious alarm).

The generic function can be controlled based on:

- 1 specific probe, or
- difference between 2 suitably configured probes, or
- minimum, maximum or average between 2 suitably configured probes.

⚠ Caution: the controller cannot verify the consistency of the settings, if two analogue functions are mistakenly assigned to the same analogue inputs or the same digital output.

5.9.1 Enabling

The generic functions can be enabled as always active or during a certain unit operating status, as set by parameters GFS_, GFM_E, GFA_E.

User	Code	Description	Def	Min	Max	UOM
S	GFS_E	Generic stepped function, enable - see GFA_E	0	0	12	-
S	GFM_E	Generic modulating function, enable - see GFA_E	0	0	12	-
S	GFA_E	Generic alarm function: enable	0	0	13	-
	0	Always	7			High pressure alarm
	1	Unit ON	8			Low pressure alarm, line 1
	2	Unit OFF	9			Low pressure alarm, line 2
	3	Control ON	10			High pressure prevention active
	4	Compressor ON	11			Generic alarm active
	5	External alarm from digital input	12			Generic warning active
	6	Unit OFF due to alarm	13			All compressors OFF

Tab. 5.ai

Assign control probe

µRack allows up to 2 control probes to be selected for each generic function, from those available, using parameters GFS_1, GFS_2, GFM_1, GFM_2, GFA_1, GFA_2. Furthermore, for generic functions with on/off or modulating output, the control variable can also be the difference between the two of the configured probes, the maximum or minimum value or the average between the two, as set using parameters GFS_F and GFM_F.

User	Code	Description	Def	Min	Max	UOM
S	GFS_1	Generic stepped function, control probe 1- see GFA_1	0	0	10	-
S	GFS_2	Generic stepped function, control probe 2- see GFA_1	0	0	10	-
S	GFM_1	Generic modulating function, control probe 1- see GFA_1	0	0	10	-
S	GFM_2	Generic modulating function, control probe 2- see GFA_1	0	0	10	-
S	GFA_1	Generic alarm function, control probe 1:	0	0	10	-
	0	Not configured	6			Discharge temperature, line 1 (SDT)
	1	Suction pressure, line 1 (SSP)	7			Discharge temperature, line 2 (SDTb)
	2	Suction pressure, line 1 (SSPB)	8			Ambient temperature (SA)
	3	Condensing pressure (SCP)	9			Outside temperature (SE)
	4	Suction temperature, line 1 (TGS)	10			Auxiliary temperature (SG)
	5	Suction temperature, line 2 (TGSB)				
S	GFA_2	Generic alarm function, control probe 2 - see GFA_1	0	0	10	-
S	GFS_F	Generic stepped function, control variable - see GFM_F	0	0	3	-
S	GFM_F	Generic modulating function, control variable:	0	0	3	-
	0	GFM_1 - GFM_2;				
	1	minimum between GFM_1 and GFM_2;				
	2	maximum between GFM_1 and GFM_2;				
	3	average between GFM_1 and GFM_2.				

Tab. 5.aj

Notice: the generic probe set using parameter /FG can be configured as a temperature probe, setting parameters /P1 and /P4 appropriately.

5.9.2 On/Off output

The operating principle of the generic On/Off function is shown in the figure: A set point GFS_S and a differential GFS_D can be set for the activation of the digital output configured using parameter DoS. The activation logic can be direct or reverse, as configured using parameter GFS_T.

User	Code	Description	Def	Min	Max	UOM	User terminal
S	GFS_T	Generic stepped function, control type - see GFM_T	0	0	1	-	NO
S	GFS_S	Generic stepped function, set point	0	-50	200	-	NO
S	GFS_D	Generic stepped function, differential	0	0	99.9	-	NO
S	GFS_F	Generic stepped function, control variable - see GFM_F	0	0	3	-	NO
S	DOS	Assign generic step function digital output - see DoA1	0	0	6	-	NO

Tab. 5.ak

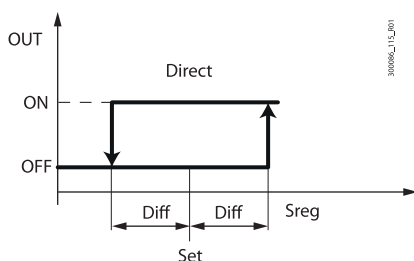

Fig. 5.v

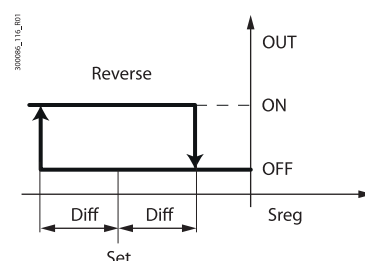

Fig. 5.w

Ref.	Description
Set	Set point
Diff	Differential
Sreg	GFS_1 - GFS_2 or maximum, minimum or average between GFS_1 and GFS_2
OUT	Digital output

Tab. 5.al

5.9.3 Modulating output

The operation of the modulating function is shown in the figure. A set point GFM_S and a differential GFM_D can be set for the activation of the modulating output configured using parameter /Ad. The activation logic can be direct or reverse, as configured using parameter GFS_T (direct operation only is shown in the figure).

Control can be proportional only or PID, setting parameters GFM_Kp, GFM_Td and GFM_Ti accordingly.

A cut-off differential GFM_CD can also be set, with a hysteresis GFM_H, and the output can be limited between a minimum GFM_Min and a maximum GFM_Max.

User	Code	Description	Def	Min	Max	UOM	User terminal
S	GFM_T	Generic modulating function, control type 0= Direct, 1= Reverse	0	0	1	-	NO
S	GFM_S	Generic modulating function, set point	0	-50	200	-	NO
S	GFM_D	Generic modulating function, differential	0	0	99.9	-	NO
S	GFM_Kp	Generic modulating function, proportional gain	0	0	100	-	NO
S	GFM_Td	Generic modulating function, derivative time	0	0	100	-	NO
S	GFM_Ti	Generic modulating function, integral time	0	0	900	-	NO
S	GFM_CD	Generic modulating function: cut-off differential	0	0	20	-	NO
S	GFM_H	Generic modulating function, hysteresis	0	0	20	-	NO
S	GFM_Max	Generic modulating function, maximum output value	0	0	100	-	NO
S	GFM_Min	Generic modulating function, minimum output value	0	0	100	-	NO
S	GFM_F	Generic modulating function: control function 0= GFM_1-GFM_2 1= Minimum value between GFM_1 and GFM_2 2= Maximum value between GFM_1 and GFM_2 3= Average value between GFM_1 and GFM_2	0	0	3	-	NO
S	/AD	Assign analogue output for generic modulating function: 0= function disabled; 1 = analogue output 1 (Y1); 2 = analogue output 2 (Y2).	0	0	2	-	NO

Tab. 5.am

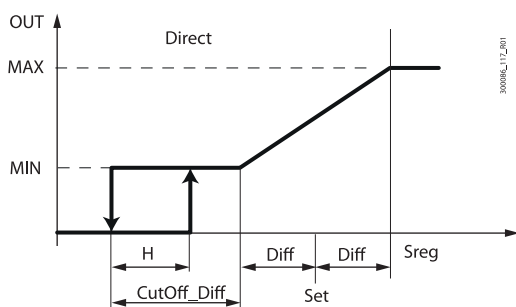

Fig. 5.x

Ref.	Description
Set	Set point
Diff	Differential
H	Hysteresis
Sreg	GFM_1 - GFM_2 or maximum, minimum or average between GFM_1 and GFM_2
OUT	Digital output
CutOff_Diff	Cut-off differential

Tab. 5.an

5.9.4 Generic alarm

The generic alarm can be activated for two reasons, after the delay (GFA_De):

1. switching of the digital input, assigned by parameter DIs: the display shows "GHI"
2. if the difference between the values of the control probes GFA_1 - GFA_2 exceeds the high threshold GFA_Hth or low threshold GFA_Lth: the display shows GHI or GLO respectively.

Notice: check that the alarm is generated by only one of the two causes.

Notice: the generic alarm can be configured as a warning or a serious alarm by setting parameter GFA_AIType.

The generic alarm function reset can be configured as: automatic (default), semi-automatic or manual, as set by parameter GFA_r.

For semi-automatic reset, it is possible to set the number of occurrences GFA_n of the alarm and corresponding time interval GFA_P before requiring manual reset directly on the display, via supervisor or APPLICA.

When a generic alarm occurs, the μ Rack controller can stop control, reduce capacity or force the fans to maximum speed, based on the setting of parameter GFA_AA.

The figure shows the behaviour of this alarm.

User	Code	Description	Def	Min	Max	UOM	User terminal
S	Dis	Assign generic alarm digital input 0 = Function disabled 1 = digital input 1 (ID1) 2 = digital input 2 (ID2) 3 = digital input 3 (ID3) 4 = digital input 4 (ID4) 5 = digital input 5 (ID5) 6 = digital input 6 (ID6)	0	0	6	-	NO
S	GFA_AllType	Generic alarm function, alarm type 0= Signal only, 1 = Serious alarm	0	0	1	-	NO
S	GFA_AA	Generic alarm function, action taken 0= no action 1= stop control 2= reduce capacity 3= fans at max speed	0	0	3	-	NO
S	GFA_r	Generic alarm function, reset type 0= automatic 1= semi-automatic 2= manual	0	0	2	-	NO
S	GFA_n	Generic alarm function, number of attempts before switching from semi-automatic to manual	0	0	99	-	NO
S	GFA_P	Generic alarm function, evaluation period for switching from semi-automatic to manual	0	0	999	min	NO
S	GFA_De	General alarm function, delay	0	0	30,000	s	NO
S	GFA_D	Generic alarm function, differential	0	0	99.9	-	NO
S	GFA_Hth	General alarm function, high threshold	0	-50	200	-	NO
S	GFA_Lth	General alarm function, low threshold	0	-50	200	-	NO

Tab. 5.ao

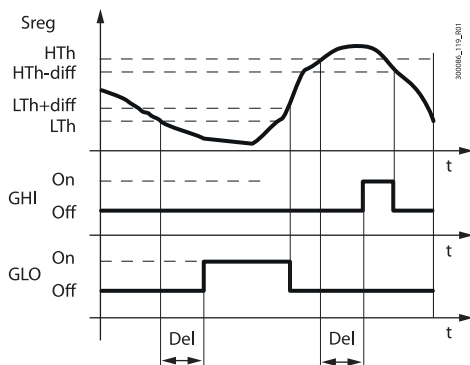

Fig. 5.y

Ref.	Description
Lth	Low temperature threshold
HTh	High temperature threshold
diff	Differential
Del	Delay
t	Time
Sreg	GFA_1 - GFA_2
GHI	Display alarm on exceeding the high threshold
GLO	Display alarm on exceeding the low threshold

Tab. 5.ap

Example

Display of the generic alarm when exceeding the thresholds.



Fig. 5.z

Generic warning function (prevent)

Before the generic alarm function is activated, a warning signal with automatic reset can also be enabled. Parameters GFA_1 and GFA_2 define the activation conditions for both functions.

The meaning of the other parameters is exactly the same as the corresponding parameters for the generic alarm function.

User	Code	Description	Def	Min	Max	UOM	User terminal
S	GFA_We	Generic alarm function, enable warning 0= disabled; 1= enabled	0	0	1	-	NO
S	GFA_WA	Generic alarm function, action taken on warning 0= no action 1= stop control 2= reduce capacity 3= fans at max speed	0	0	3	-	NO
S	GFA_WDe	Generic alarm function, warning delay	0	0	30000	s	NO
S	GFA_WD	Generic alarm function, warning differential	0	0	99.9	-	NO
S	GFA_WHth	General alarm function, high warning threshold	0	-50	200	-	NO
S	GFA_WLth	General alarm function, low warning threshold	0	-50	200	-	NO

Tab. 5.aq

6. PARAMETER TABLE

Notice:

- Access levels: U = User (free access without password); S = Service; M = Manufacturer. The user level provides access without password, the other levels have default passwords 44 and 77 respectively. If a parameter is visible for one level, it is also visible to the higher levels.
- Display: the dash indicates that the parameter cannot be accessed from the user terminal but rather only via the app or commissioning tool, otherwise the code represents the menu branch (see "Programming menu" for details).
- R/W = read/write parameters; R = read-only parameters.
- The parameter code shown in the apps and in the commissioning tools; on the 7-segment display, some letters may be displayed in upper/lower case, for example "B" -> "b", "T" -> "t", etc.
- Visibility: some parameters are visible on the 7-segment display based on the value of other parameters.
- Values marked with a (*) may not be displayed correctly on the 7-segment display, as the display limits are -999/999.

6.1 Unit

User	Display	Code	Description	Def.	Min.	Max.	UOM	Visibility
U	Unl	/5	Unit of measure (0= °C/barg; 1= °F/psig)	0	0	1	-	
U	Unl	H8	Enable buzzer (0= disabled; 1= enabled)	1	0	1	-	
U	Unl	on	Line 1 ON/OFF from keypad (0= OFF; 1= ON)	0	0	1	-	ONK= 1
U	Unl	onb	Line 2 ON/OFF from keypad - see on	0	0	1	-	ONK= 1, nC2 > 0
U	Unl	ONK	Enable ON/OFF from keypad (0= disabled; 1= enabled)	1	0	1	-	
S	StG -> BMS	ons	Enable ON/OFF from supervisor (0= disabled; 1= enabled)	0	0	1	-	
M	StG -> PSd	PDM	Manufacturer password	77	000	999	-	
S	StG -> PSd	PDS	Service password	44	000	999	-	
M	-	rSC	Reset to CAREL default values	0	0	1	-	
S	-	vrt	Control by pressure or temperature (0= pressure; 1= temperature)	0	0	1	-	

Tab. 6.a

6.2 Compressors

User	Display	Code	Description	Def.	Min.	Max.	UOM	Visibility
Configuration								
M	Unl	PH	Type of refrigerant used in the unit 0: Custom 8: R600 16: R413A 24: HTR01 32: R447A 40: R454B 1: R22 9: R600a 17: R422A 25: HTR02 33: R448A 41: R458A 2: R134a 10: R717 18: R423A 26: R23 34: R449A 42: R407H 3: R404A 11: R744 19: R407A 27: HFO1234yf 35: R450A 43: R454A 4: R407C 12: R728 20: R427A 28: HFO1234ze 36: R452A 44: R454C 5: R410A 13: R1270 21: R245Fa 29: R455A 37: R508B 45: R470A 6: R507A 14: R417A 22: R407F 30: R170 38: R452B 46: R515B 7: R290 15: R422D 23: R32 31: R442A 39: R513A 47: R466	3	0	47		
S	Unl	c0	Delay when restarting after blackout	0	0	999	-	
M	CL1 -> CFG	C1	Minimum time between two consecutive starts of each compressor on line 1	360	0	999	s	nC > 0
M	CL2 -> CFG	C1B	Minimum time between two consecutive starts of each compressor on line 2	360	0	999	s	nC2 > 0
M	CL1 -> CFG	C2	Minimum OFF time for each compressor on line 1	120	0	999	s	nC > 0
M	CL2 -> CFG	C2B	Minimum OFF time for each compressor on line 2	120	0	999	s	nC2 > 0
M	CL1 -> CFG	C3	Minimum ON time for each compressor on line 1	10	0	999	s	nC > 0
M	CL2 -> CFG	C3B	Minimum ON time for each compressor on line 2	10	0	999	s	nC2 > 0
M	CL1 -> CFG	C1T	First compressor type, line 1 0= ON-OFF 2= Digital Scroll™ 4= 3 steps 33/66/100 1= inverter 3= 2 steps 50/100	0	0	4		nC > 0
M	CL2 -> CFG	C1TB	First compressor type, line 2 (see C1T)	0	0	4		nC > 0
M	CL1 -> CFG	CLD	Delay between OFF requests for steps/compressors on line 1	10	0	999	s	nC > 0
M	CL2 -> CFG	CLDB	Delay between OFF requests for steps/compressors on line 2	120	0	999	s	nC2 > 0
M	CL1 -> CFG	CLU	Delay between ON requests for steps/compressors on line 1	30	0	999	s	nC > 0
M	CL2 -> CFG	CLUB	Delay between ON requests for steps/compressors on line 2	10	0	999	s	nC2 > 0
M	CL1 -> CFG	cmF	Maximum inverter control frequency, line 1	50	CnF	150	hz	nC > 0, C1T = 1
M	CL2 -> CFG	cmFB	Maximum inverter control frequency, line 2	50	CnFB	150	hz	nC2 > 0, C1TB = 1
M	CL1 -> CFG	cnF	Minimum inverter control frequency, line 1	30	0	CMF	hz	nC > 0, C1T = 1
M	CL2 -> CFG	cnFB	Minimum inverter control frequency, line 2	30	0	CMFB	hz	nC2 > 0, C1TB = 1
M	CL1 -> CFG	CRF	Rated inverter control frequency, line 1 (note: CS1 capacity refers to this frequency)	50	1	150	hz	nC > 0, C1T = 1
M	CL2 -> CFG	CRFB	Rated inverter control frequency, line 2 (note: CS1B capacity refers to this frequency)	50	1	150	hz	nC2 > 0, C1TB = 1

User	Display	Code	Description	Def.	Min.	Max.	UOM	Visibility
M	CL1 -> CFG	Cro	Compressor rotation type (0 = FIFO; 1 = LIFO; 2 = time)	0	0	2	-	nC > 0
S	CL1 -> CFG	CPL	End pump down threshold for line 1	1/ 14.5	-1/ -14.5	SP	barg/ psig	nC > 0, CPT > 0
S	CL2 -> CFG	CPLB	End pump down threshold for line 2	1/ 14.5	-1/ -14.5	SPB	barg/ psig	nC2 > 0, CPT > 0
S	CL1 -> CFG	CPT	Maximum pump down duration, line 1 (0 = pump down disabled)	0	0	60	min	nC > 0
S	CL2 -> CFG	CPTB	Maximum pump down duration, line 2 (0 = pump down disabled)	0	0	60	min	nC2 > 0
M	CL1 -> CFG	CS1	Capacity of the first compressor, line 1	10	0	999	kW	nC > 0
M	CL1 -> CFG	CS2	Capacity of the second compressor, line 1	10	0	999	kW	nC > 0
M	CL1 -> CFG	CS3	Capacity of the third compressor, line 1	10	0	999	kW	nC > 0
M	CL1 -> CFG	CS4	Capacity of the fourth compressor, line 1	10	0	999	kW	nC > 0
M	CL2 -> CFG	CS1B	Capacity of the first compressor, line 2	10	0	999	kW	nC2 > 0
M	CL2 -> CFG	CS2B	Capacity of the second compressor, line 2	10	0	999	kW	nC2 > 0
S	CL1 -> CFG	DPc	Capacity request during line 1 emergency operation	70	0	100	%	
S	CL2 -> CFG	DPcb	Capacity request during line 2 emergency operation	70	0	100	%	
S	CL1 -> CFG	EC1	Enable compressor 1 line 1 (0 = disabled; 1 = enabled)	1	0	1	-	nC > 0
S	CL1 -> CFG	EC2	Enable compressor 2 line 1 – see EC1	1	0	1	-	nC > 0
S	CL1 -> CFG	EC3	Enable compressor 3 line 1 – see EC1	1	0	1	-	nC > 0
S	CL1 -> CFG	EC4	Enable compressor 4 line 1 – see EC1	1	0	1	-	nC > 0
S	CL2 -> CFG	EC1B	Enable compressor 1 line 2 – see EC1	1	0	1	-	nC2 > 0
S	CL2 -> CFG	EC2B	Enable compressor 2 line 2 – see EC1	1	0	1	-	nC2 > 0
M	CL1 -> CFG	iCD	Inverter deceleration time from 100% to 0% speed (line 1)	60	1	360	s	nC > 0, C1T = 1
M	CL2 -> CFG	iCDB	Inverter deceleration time from 100% to 0% speed (line 2)	60	1	360	s	nC2 > 0, C1TB = 1
M	CL1 -> CFG	iCU	Inverter acceleration time from 0% to 100% speed (line 1)	100	1	360	s	nC > 0, C1T = 1
M	CL2 -> CFG	iCUB	Inverter acceleration time from 0% to 100% speed (line 2)	100	1	360	s	nC2 > 0, C1TB = 1
S	CL1 -> CFG	Mc1	Manual mode, compressor 1 line 1 ON/OFF compressor Compressor with 0-50-100% steps Compressor with 0-33-66-100% steps Compressor with inverter or Digital scroll™ 0 = automatic operation 1 = OFF 2 = ON 0 = automatic operation 1 = OFF 2 = 50% 3 = 100% 0 = automatic operation 1 = OFF 2 = 33% 3 = 66% 4 = 100% 0 = automatic operation 1 = OFF 2 = 2%, ... 100 = 100%	0	0	100	-	nC > 0
S	CL1 -> CFG	Mc2	Manual mode, compressor 2 line 1 (0 = automatic, 1= OFF, 2= ON)	0	0	2	-	nC > 0
S	CL1 -> CFG	Mc3	Manual mode, compressor 3 line 1 – see Mc2	0	0	2	-	nC > 0
S	CL1 -> CFG	Mc4	Manual mode, compressor 4 line 1 – see Mc2	0	0	2	-	nC > 0
S	CL2 -> CFG	Mc1b	Manual mode, compressor 1 line 2 – see Mc1	0	0	100	-	nC2 > 0
S	CL2 -> CFG	Mc2b	Manual mode, compressor 2 line 2 – see Mc2	0	0	2	-	nC2 > 0
M	CL1 -> CFG	nC	Number of compressors, line 1	2	0	4	-	
M	CL2 -> CFG	nC2	Number of compressors, line 2 (0= line 2 not present)	0	0	2	-	
S	OtH -> OIL	orA	Stabilisation time for oil recovery, line 1	600	0	9999	s	nC > 0
S	OtH -> OIL	orF	Force ON time for oil recovery, line 1	300	0	9999	s	nC > 0
S	OtH -> OIL	orn	Minimum compressor capacity for oil recovery, line 1	40	0	100	%	nC > 0
S	OtH -> OIL	orP	Pause time for oil recovery, line 1	600	0	9999	s	nC > 0
S	OtH -> OIL	orU	Delay time for oil recovery, line 1	60	0	999	min	nC > 0
S	OtH -> OIL	orAb	Stabilisation time for oil recovery, line 2	600	0	9999	s	nC2 > 0
S	OtH -> OIL	orFb	Force ON time for oil recovery, line 2	300	0	9999	s	nC2 > 0
S	OtH -> OIL	ornb	Minimum compressor capacity for oil recovery, line 2	40	0	100	%	nC2 > 0
S	OtH -> OIL	orPb	Pause time for oil recovery, line 2	600	0	9999	s	nC2 > 0
S	OtH -> OIL	orUb	Delay time for oil recovery, line 2	60	0	999	min	nC2 > 0
Control								
S	CL1 -> rEG	CRC	Force off threshold for dead band control, line 1	-1/ -14.5	-1/ -14.5	20/290	barg/ psig	nC > 0, CRT = 1
S	CL1 -> rEG	CRC_T	Force off threshold for dead band control, line 1, expressed as a temperature	-1/ 30.2	-99.9/ -147.8	99.9/ 212.8	°C/°F	
S	CL2 -> rEG	CRCB	Force off threshold for dead band control, line 2	-1/ -14.5	-1/ -14.5	20/290	barg/ psig	nC2 > 0, CRT = 1
S	CL2 -> rEG	CRCB_T	Force off threshold for dead band control, line 2, expressed as a temperature	-1/ 30.2	-99.9/ -147.8	99.9/ 212.8	°C/°F	
S	CL1 -> rEG	CRM	Maximum time in which the requested capacity reaches 100% with dead band control, line 1	60	CRn	999	s	nC > 0, CRT = 1
S	CL2 -> rEG	CRMB	Maximum time in which the requested capacity reaches 100% with dead band control, line 2	60	CRnB	999	s	nC2 > 0, CRTB = 1
S	CL1 -> rEG	CRn	Minimum time in which the requested capacity reaches 100% with dead band control, line 1	20	0	CRM	s	nC > 0, CRT = 1
S	CL2 -> rEG	CRnB	Minimum time in which the requested capacity reaches 100% with dead band control, line 2	20	0	CRMB	s	nC2 > 0, CRTB = 1

User	Display	Code	Description	Def.	Min.	Max.	UOM	Visibility
S	CL1 -> rEG	CRP	Minimum time in which the requested capacity reaches 0% with dead band control, line 1	10	0	CRQ	s	nC > 0, CRT = 1
S	CL2 -> rEG	CRPB	Minimum time in which the requested capacity reaches 0% with dead band control, line 2	10	0	CRQB	s	nC2 > 0, CRT = 1
S	CL1 -> rEG	CRQ	Maximum time in which the requested capacity reaches 0% with dead band control, line 1	60	CRP	999	s	nC > 0, CRT = 1
S	CL2 -> rEG	CRQB	Maximum time in which the requested capacity reaches 0% with dead band control, line 2	60	CRPB	999	s	nC2 > 0, CRT = 1
S	CL1 -> rEG	CRT	Compressor control type, line 1 (0 = P+; 1 = dead band)	1	0	1		nC > 0
S	CL2 -> rEG	CRTb	Compressor control type, line 2 (0 = P+; 1 = dead band)	1	0	1		nC2 > 0
S	CL1 -> rEG	Cti	P+I control integral time, line 1	600	0	999	s	nC > 0, CRT = 0
S	CL2 -> rEG	CTiB	P+I control integral time, line 2	600	0	999	s	nC2 > 0, CRT = 0
S	CL1 -> rEG	RDD	Decrease differential for dead band control, line 1	0.5/7.2	0.5/7.2	20/290	Δbarg/Δpsig	nC > 0, CRT = 1
S	CL1 -> rEG	RDD_T	Decrease differential for dead band control, line 1, expressed as a temperature	5/9	0	99.9/179.8	°C/°F	
S	CL2 -> rEG	Rddb	Decrease differential for dead band control, line 2	0.5/7.2	0.5/7.2	20/290	Δbarg/Δpsig	nC2 > 0, CRT = 1
S	CL2 -> rEG	Rddb_T	Decrease differential for dead band control, line 2, expressed as a temperature	5/9	0	99.9/179.8	°C/°F	
S	CL1 -> rEG	RDi	Increase differential for dead band control, line 1	0.5/7.2	0.5/7.2	20/290	Δbarg/Δpsig	nC > 0, CRT = 1
S	CL1 -> rEG	RDi_T	Increase differential for dead band control, line 1, expressed as a temperature	5/9	0	99.9/179.8	°C/°F	
S	CL2 -> rEG	RDiB	Increase differential for dead band control, line 2	0.5/7.2	0.5/7.2	20/290	Δbarg/Δpsig	nC2 > 0, CRT = 1
S	CL2 -> rEG	RDiB_T	Increase differential for dead band control, line 2, expressed as a temperature	5/9	0	99.9/179.8	°C/°F	
S	CL1 -> rEG	RDP	Control differential, line 1	0.5/7.2	0	20/290	Δbarg/Δpsig	nC > 0
S	CL1 -> rEG	RDP_T	Control differential, line 1, expressed as a temperature	5/9	0	99.9/179.8	°C/°F	
S	CL2 -> rEG	RDPB	Control differential, line 2	0.5/7.2	0	20/290	Δbarg/Δpsig	nC2 > 0
S	CL2 -> rEG	RDPB_T	Control differential, line 2, expressed as a temperature	5/9	0	99.9/179.8	°C/°F	
U	CL1 -> rEG	SP	Control set point, line 1	1/14.5	SPL	SPH	barg/psig	nC > 0
U	CL1 -> rEG	Spt	Control set point, line 1, expressed as a temperature	1/33.8	SPL_T	SPH_T	°C/°F	
U	CL2 -> rEG	SPB	Control set point, line 2	1/14.5	SPLB	SPHB	barg/psig	nC2 > 0
U	CL2 -> rEG	SPbt	Control set point, line 2, expressed as a temperature	1/33.8	SPLB_T	SPHB_T	°C/°F	
S	-	SPE	Control set point offset for time bands, line 1	0	-9.9/-143.5	9.9/143.5	Δbarg/Δpsig	
S	-	SPE_T	Control set point offset for time bands, line 1, expressed as a temperature	0	-99.9/-179.8	99.9/179.8	Δ°C/Δ°F	
S	-	SPEb	Control set point offset for time bands, line 2	0	-9.9/-143.5	9.9/143.5	Δbarg/Δpsig	
S	-	SPEb_T	Control set point offset for time bands, line 2, expressed as a temperature	0	-99.9/-179.8	99.9/179.8	Δ°C/Δ°F	
M	CL1 -> rEG	SPH	Control set point maximum limit, line 1	9.3/134.8	SPL	/UT	barg/psig	nC > 0
M	CL1 -> rEG	SPH_T	Control set point maximum limit, line 1, expressed as a temperature	9.3/48.7	SPL_T	99.9/211.8	°C/°F	
M	CL2 -> rEG	SPHB	Control set point maximum limit, line 2	9.3/134.8	SPLB	/UTB	barg/psig	nC2 > 0
M	CL2 -> rEG	SPHB_T	Control set point maximum limit, line 2, expressed as a temperature	9.3/48.7	SPLB_T	99.9/211.8	°C/°F	
M	CL1 -> rEG	SPL	Control set point minimum limit, line 1	0.1/1.4	/LT	SPH	barg/psig	nC > 0
M	CL1 -> rEG	SPL_T	Control set point minimum limit, line 1, expressed as a temperature	-50/-58	-50/-58	SPH_T	°C/°F	
M	CL2 -> rEG	SPLB	Control set point minimum limit, line 2	0.1/1.4	/LTB	SPHB	barg/psig	nC2 > 0
M	CL2 -> rEG	SPLB_T	Control set point minimum limit, line 2, expressed as a temperature	-50/-58	-50/-58	SPHB_T	°C/°F	
S	CL1 -> rEG	SPo	Control set point offset for compensation by digital input, line 1	0	-9.9/-143.5	9.9/143.5	Δbarg/Δpsig	nC > 0
S	CL1 -> rEG	SPo_T	Control set point offset for compensation by digital input, line 1, expressed as a temperature	0	-99.9/-179.8	99.9/179.8	Δ°C/Δ°F	
S	CL2 -> rEG	SPob	Control set point offset for compensation by digital input, line 2	0	-9.9/-143.5	9.9/143.5	Δbarg/Δpsig	nC2 > 0
S	CL2 -> rEG	SPob_T	Control set point offset for compensation by digital input, line 2	0	-99.9/-179.8	99.9/179.8	Δ°C/Δ°F	
Energy saving								
S	CL1 -> ESv	FLE	Enable floating suction set point, line 1 (0 = disabled; 1 = enabled)	0	0	1	-	
S	CL2 -> ESv	FLEb	Enabling floating suction set point, line 2 – see FLE	0	0	1	-	

User	Display	Code	Description	Def.	Min.	Max.	UOM	Visibility
S	CL1 -> ESv	FLH	Maximum floating suction set point, line 1	0	FLL	SPH	barg/ psig	
S	CL1 -> ESv	FLH_T	Maximum floating suction set point, line 1, expressed as a temperature	0/ 32	FLL_T	SPH_T	°C/°F	
S	CL2 -> ESv	FLHb	Maximum floating suction set point, line 2	0	FLLb	SPHB	barg/ psig	
S	CL2 -> ESv	FLHb_T	Maximum floating suction set point, line 2, expressed as a temperature	0/ 32	FLLb_T	SPHB_T	°C/°F	
S	CL1 -> ESv	FLL	Minimum floating suction set point, line 1	0	SPL	FLH	barg/ psig	
S	CL1 -> ESv	FLL_T	Minimum floating suction set point, line 1, expressed as a temperature	0/ 32	SPL_T	FLH_T	°C/°F	
S	CL2 -> ESv	FLLb	Minimum floating suction set point, line 2	0	SPLb	FLHb	barg/ psig	
S	CL2 -> ESv	FLLb_T	Minimum floating suction set point, line 2, expressed as a temperature	0/ 32	SPLb_T	FLHb_T	°C/°F	
S	CL1 -> ESv	FLM	Floating suction set point maximum variation, line 1	1/ 14.5	0	9.9/ 143.5	Δbarg/ Δpsig	
S	CL1 -> ESv	FLM_T	Floating suction set point maximum variation, line 1, expressed as a temperature	1/ 1.8	-99.9/ -179.8	99.9/ 179.8	Δ°C/ Δ°F	
S	CL2 -> ESv	FLMb	Floating suction set point maximum variation, line 2	1/ 14.5	0	9.9/ 143.5	Δbarg/ Δpsig	
S	CL2 -> ESv	FLMb_T	Floating suction set point maximum variation, line 2, expressed as a temperature	1/ 1.8	-99.9/ -179.8	99.9/ 179.8	Δ°C/ Δ°F	
S	CL1 -> ESv	FLt	Floating suction set point sampling time, line 1	0	0	999	min	
S	CL2 -> ESv	FLtb	Floating suction set point sampling time, line 2	0	0	999	min	

Digital Scroll™

User	Display	Code	Description	Def.	Min.	Max.	UOM	Visibility
M	-	DigitalScroll_1.DefVlvCycleT	Default valve cycle time – Digital Scroll™ line 1	12	0	65535	s	
M	-	DigitalScroll_1.DefVlvOFF_T	Default valve OFF time – Digital Scroll™ line 1	10	0	65535	s	
M	-	DigitalScroll_1.DefVlvON_T	Default valve ON time – Digital Scroll™ line 1	2	0	65535	s	
M	-	DigitalScroll_1.MaxVlvCycleT	Maximum valve cycle time – Digital Scroll™ line 1	20	0	65535	s	
M	-	DigitalScroll_1.MaxVlvOFF_T	Maximum valve OFF time – Digital Scroll™ line 1	20	0	65535	s	
M	-	DigitalScroll_1.MaxVlvON_T	Maximum valve ON time – Digital Scroll™ line 1	18	0	65535	s	
M	-	DigitalScroll_1.MinVlvCycleT	Minimum valve cycle time – Digital Scroll™ line 1	12	0	65535	s	
M	-	DigitalScroll_1.MinVlvOFF_T	Minimum valve OFF time – Digital Scroll™ line 1	2	0	65535	s	
M	-	DigitalScroll_1.MinVlvON_T	Minimum valve ON time – Digital Scroll™ line 1	0	0	65535	s	
M	-	DigitalScroll_1.StartUpPwr1	Starting capacity – stage 1 – Digital Scroll™ line 1	0	0	100	%	
M	-	DigitalScroll_1.StartUpPwr2	Starting capacity – stage 2 – Digital Scroll™ line 1	50	0	100	%	
M	-	DigitalScroll_1.StartUpPwr3	Starting capacity – stage 3 – Digital Scroll™ line 1	100	0	100	%	
M	-	DigitalScroll_1.StartUpT1	Starting time – stage 1 – Digital Scroll™ line 1	4	0	65535	s	
M	-	DigitalScroll_1.StartUpT2	Starting time – stage 2 – Digital Scroll™ line 1	180	0	65535	s	
M	-	DigitalScroll_1.StartUpT3	Starting time – stage 3 – Digital Scroll™ line 1	60	0	65535	s	
M	-	DigitalScroll_2.DefVlvCycleT	Default valve cycle time – Digital Scroll™ line 2	12	0	65535	s	
M	-	DigitalScroll_2.DefVlvOFF_T	Default valve OFF time – Digital Scroll™ line 2	10	0	65535	s	
M	-	DigitalScroll_2.DefVlvON_T	Default valve ON time – Digital Scroll™ line 2	2	0	65535	s	
M	-	DigitalScroll_2.MaxVlvCycleT	Maximum valve cycle time – Digital Scroll™ line 2	20	0	65535	s	
M	-	DigitalScroll_2.MaxVlvOFF_T	Maximum valve OFF time – Digital Scroll™ line 2	20	0	65535	s	
M	-	DigitalScroll_2.MaxVlvON_T	Maximum valve ON time – Digital Scroll™ line 2	18	0	65535	s	
M	-	DigitalScroll_2.MinVlvCycleT	Minimum valve cycle time – Digital Scroll™ line 2	12	0	65535	s	
M	-	DigitalScroll_2.MinVlvOFF_T	Minimum valve OFF time – Digital Scroll™ line 2	2	0	65535	s	
M	-	DigitalScroll_2.MinVlvON_T	Minimum valve ON time – Digital Scroll™ line 2	0	0	65535	s	
M	-	DigitalScroll_2.StartUpPwr1	Starting capacity – stage 1 – Digital Scroll™ line 2	0	0	100	%	
M	-	DigitalScroll_2.StartUpPwr2	Starting capacity – stage 2 – Digital Scroll™ line 2	50	0	100	%	
M	-	DigitalScroll_2.StartUpPwr3	Starting capacity – stage 3 – Digital Scroll™ line 2	100	0	100	%	
M	-	DigitalScroll_2.StartUpT1	Starting time – stage 1 – Digital Scroll™ line 2	4	0	65535	s	
M	-	DigitalScroll_2.StartUpT2	Starting time – stage 2 – Digital Scroll™ line 2	180	0	65535	s	
M	-	DigitalScroll_2.StartUpT3	Starting time – stage 3 – Digital Scroll™ line 2	60	0	65535	s	

Operating hours

S	CL1 -> rEG	HMP	Maintenance alarm threshold for line 1 compressors, expressed in hundreds of hours (0 = alarm disabled)	0	0	999	hx100	nC > 0
S	CL2 -> rEG	HMPB	Maintenance alarm threshold for line 2 compressors, expressed in hundreds of hours (0 = alarm disabled)	0	0	999	hx100	nC2 > 0
S	CL1 -> rEG	HMR1	Reset operating hours, compressor 1 line 1	0	0	1	-	nC > 0
S	CL1 -> rEG	HMR2	Reset operating hours, compressor 2 line 1	0	0	1	-	nC > 0
S	CL1 -> rEG	HMR3	Reset operating hours, compressor 3 line 1	0	0	1	-	nC > 0
S	CL1 -> rEG	HMR4	Reset operating hours, compressor 4 line 1	0	0	1	-	nC > 0
S	CL2 -> rEG	HMRA	Reset operating hours, compressor 1 line 2	0	0	1	-	nC2 > 0
S	CL2 -> rEG	HMRB	Reset operating hours, compressor 2 line 2	0	0	1	-	nC2 > 0

Tab. 6.b

6.3 Fans

User	Display	Code	Description	Def.	Min.	Max.	UOM	Visibility	
Configuration									
S	FAn -> CFG	DfC	Capacity request during condenser emergency operation	70	0	100	%		
S	FAn -> CFG	EF1	Enable fan 1 (0= disabled; 1= enabled)	1	0	1	-	nF > 0	
S	FAn -> CFG	EF2	Enable fan 2 – see EF1	1	0	1	-	nF > 0	
S	FAn -> CFG	EF3	Enable fan 3 – see EF1	1	0	1	-	nF > 0	
S	FAn -> CFG	EF4	Enable fan 4 – see EF1	1	0	1	-	nF > 0	
M	FAn -> CFG	FHC	Condenser fan inverter maximum speed	100	FLC	100	%		
M	FAn -> CFG	FLC	Condenser fan inverter minimum speed	20	0	FHC	%		
S	FAn -> CFG	FLo	Minimum condenser fan inverter output	40	0	100	%		
S	FAn -> CFG	FSE	Minimum outside temperature threshold for disabling modulating fan speed up	0/ 32	-50/ -58	50/ 122	°C/°F	nF > 0	
S	FAn -> CFG	FSt	Speed up time when starting the fan	5	0	60	s	nF > 0	
S	FAn -> CFG	FSU	Enable modulating fan speed up (0= disabled; 1= enabled)	0	0	1	-	nF > 0	
S	FAn -> CFG	FTI	Integral time for P+I condenser fan control	600	0	999	s	nF > 0	
M	FAn -> CFG	IFd	Condenser fan inverter deceleration time from 100% to 0% speed	10	1	360	s		
M	FAn -> CFG	IFL1	Type of fan 1 (0 = On/Off; 1 = inverter)	0	0	1	-		
M	FAn -> CFG	iFU	Condenser fan inverter acceleration time from 0% to 100% speed	2	1	360	s		
S	FAn -> CFG	MEF	Manual mode, fan 1 On/Off fan	0	0	100	-	nF > 0	
			Inverter fan						
				0= automatic operation; 1= Off; 2= On.					
				0= automatic operation; 1= Off; 2= 2%, ..., 100= 100%.					
S	FAn -> CFG	MEF2	Manual mode, fan 2 (0= automatic; 1= Off; 2= On)	0	0	2	-	nF > 0	
S	FAn -> CFG	MEF3	Manual mode, fan 3 (0= automatic; 1= Off; 2= On)	0	0	2	-	nF > 0	
S	FAn -> CFG	MEF4	Manual mode, fan 4 (0= automatic; 1= Off; 2= On)	0	0	2	-	nF > 0	
M	FAn -> CFG	nF	Number of condenser fans	2	0	4	-		
Control									
S	-	CtE	Fan control set point offset for compensation by time band	0	-9.9/ -143.5	9.9/ 143.5	Δbarg/ Δpsig		
S	-	CtE_T	Fan control set point offset for compensation by time band, expressed as a temperature	0	-99.9/ -179.8	99.9/ 179.8	Δ°C/ Δ°F		
S	FAn -> rEG	Cto	Fan control set point offset for compensation by digital input	0	-9.9/ -143.5	9.9/ 143.5	Δbarg/ Δpsig		
S	FAn -> rEG	Cto_T	Fan control set point offset for compensation by digital input, expressed as a temperature	0	-99.9/ -179.8	99.9/ 179.8	Δ°C/ Δ°F		
S	FAn -> rEG	F31	Fans ON with compressors ON (0 = fans ON also with compressor OFF; 1= fans ON when at least one compressor is ON)	0	0	1	-		
S	FAn -> rEG	FLD	Switch OFF delay between fans with rotation OFF request	2	0	999	s	nF > 0	
S	FAn -> rEG	FLU	Switch ON delay between fans with rotation ON request	2	0	999	s	nF > 0	
S	FAn -> rEG	FRC	Force off threshold for dead band fan control	-1/ -14.5	-1/ -14.5	20/ 290	barg/ psig		
S	-	FRC_T	Force off threshold for dead band fan control, expressed as a temperature	-50/ -58	-99.9/ -147.8	99.9/ 211.8	°C/°F		
S	FAn -> rEG	FRM	Maximum time in which the requested capacity reaches 100% with dead band fan control	60	FRn	999	s	nF > 0	
S	FAn -> rEG	FRn	Minimum time in which the requested capacity reaches 100% with dead band fan control	20	0	FRM	s	nF > 0	
S	FAn -> rEG	FRo	Fan rotation type (0= FIFO; 1= LIFO)	0	0	1	-	nF > 0	
S	FAn -> rEG	FRP	Minimum time in which the requested capacity reaches 0% with dead band fan control	10	0	FRQ	s	nF > 0	
S	FAn -> rEG	FRQ	Maximum time in which the requested capacity reaches 0% with dead band fan control	60	FRP	999	s	nF > 0	
S	FAn -> rEG	Frt	Fan control type (0= P+I; 1= dead band)	1	0	1	-	nF > 0	
S	FAn -> rEG	RDF	Condenser fan control differential	3/ 43.5	0	20/ 290	Δbarg/ Δpsig		
S	FAn -> rEG	RDF_T	Condenser fan control differential, expressed as a temperature	15/ 27	0	99.9/ 179.8	Δ°C/ Δ°F		
S	FAn -> rEG	RDFD	Decrease differential for condenser fan dead band control	0.5/ 7.2	0.5/ 7.2	20/ 290	Δbarg/ Δpsig		
S	FAn -> rEG	RDFD_T	Decrease differential for condenser fan dead band control, expressed as a temperature	0.5/ 32.9	-99.9/ -147.8	99.9/ 179.8	Δ°C/ Δ°F		
S	FAn -> rEG	RDFi	Increase differential for condenser fan dead band control	0.5/ 7.2	0.5/ 7.2	20/ 290	Δbarg/ Δpsig	-	
S	FAn -> rEG	RDFi_T	Increase differential for condenser fan dead band control, expressed as a temperature	0.5/ 32.9	-99.9/ -147.8	99.9/ 179.8	Δ°C/ Δ°F	-	
U	FAn -> rEG	STF	Condenser fan control set point	15.5/ 224.8	STFL	STFH	barg/ psig	nF > 0	
U	FAn -> rEG	STFT	Condenser fan control set point, expressed as a temperature	15.5/ 59.9	STFL_T	STFH_T	°C/°F	-	

User	Display	Code	Description	Def.	Min.	Max.	UOM	Visibility
M	FAn -> rEG	STFH	Condenser fan control set point maximum limit	25/ 362.5	STFL	/US	barg/ psig	nF > 0
M	FAn -> rEG	STFH_T	Condenser fan control set point maximum limit, expressed as a temperature	55.5/ 77	STFL_T	99.9/ 211.8	°C/°F	
M	FAn -> rEG	STFL	Condenser fan control set point minimum limit	1/ 14.5	0	STFH	barg/ psig	nF > 0
M	FAn -> rEG	STFL_T	Condenser fan control set point minimum limit, expressed as a temperature	1/ 33.8	0/ 32	STFH_T	°C/°F	-
Energy saving								
S	FAn -> ESv	FLcd	Temperature offset for floating condensing set point	10/ 18	-40/ -72	150/ 270	Δ°C/ Δ°F	nF > 0
S	FAn -> ESv	FLcE	Enable floating condensing set point (0= disabled; 1= enabled)	0	0	1	-	nF > 0
Operating hours								
S	FAn -> rEG	FMP	Maintenance alarm threshold for condenser fans, expressed in hundreds of hours (0 = alarm disabled)	0	0	320	hx100	nF > 0
S	FAn -> rEG	FMr1	Reset operating hours, fan 1	0	0	1	-	nF > 0
S	FAn -> rEG	FMr2	Reset operating hours, fan 2	0	0	1	-	nF > 0
S	FAn -> rEG	FMr3	Reset operating hours, fan 3	0	0	1	-	nF > 0
S	FAn -> rEG	FMr4	Reset operating hours, fan 4	0	0	1	-	nF > 0

Tab. 6.c

6.4 Input/Output

User	Display	Code	Description	Def.	Min.	Max.	UOM	Visibility
Analogue inputs								
M	IO -> Aln	/2	Analogue probe measurement stability (filter) 1= probe reading not delayed; ... 15= maximum probe reading delay	9	1	15	-	
U	Unl	/5	Unit of measure (0 = °C/barg; 1 = °F/psig)	0	0	1	-	-
S	IO -> Aln	/C3	Outside temperature probe calibration	0.0	-99.9/ -179.8	99.9/ 179.8	Δ°C/ Δ°F	/F3 ≠ 0
S	IO -> Aln	/CD	Suction temperature probe calibration, line 1	0.0	-99.9/ -179.8	99.9/ 179.8	Δ°C/ Δ°F	/FD ≠ 0
S	IO -> Aln	/CDB	Suction temperature probe calibration, line 2	0.0	-99.9/ -179.8	99.9/ 179.8	Δ°C/ Δ°F	/FDB ≠ 0
S	IO -> Aln	/CG	Generic probe calibration	0.0	-20/ -99.9	20/ 99.9	Δ°C/ Δ°F	/FG ≠ 0
S	IO -> Aln	/Ci	Room temperature probe calibration	0.0	-99.9/ -179.8	99.9/ 179.8	Δ°C/ Δ°F	/Fi ≠ 0
S	IO -> Aln	/Co	Discharge temperature probe calibration, line 1	0.0	-99.9/ -179.8	99.9/ 179.8	Δ°C/ Δ°F	/Fo ≠ 0
S	IO -> Aln	/Cob	Discharge temperature probe calibration, line 1	0.0	-99.9/ -179.8	99.9/ 179.8	Δ°C/ Δ°F	/Fob ≠ 0
S	IO -> Aln	/CS	Condensing temperature probe calibration	0.0	-99.9/ -1448.9	99.9/ 1448.9	Δbarg/ Δpsig	/FS ≠ 0
S	IO -> Aln	/CT	Suction pressure probe calibration, line 1	0.0	-99.9/ -1448.9	99.9/ 1448.9	Δbarg/ Δpsig	/FT ≠ 0
S	IO -> Aln	/CTB	Suction pressure probe calibration, line 2	0.0	-99.9/ -1448.9	99.9/ 1448.9	Δbarg/ Δpsig	/FTB ≠ 0
S	IO -> Aln	/F3	Assign outside temperature probe channel (0= function disabled; 1= S1; 2= S2; ...; 7= S7)	0	0	7	-	-
S	IO -> Aln	/FD	Assign line 1 suction temperature probe channel – see /F3	3	0	7	-	-
S	IO -> Aln	/FDB	Assign line 2 suction temperature probe channel – see /F3	0	0	7	-	-
S	IO -> Aln	/FG	Assign generic probe channel – see /F3	0	0	7	-	-
S	IO -> Aln	/Fi	Assign room temperature probe channel – see /F3	0	0	7	-	-
S	IO -> Aln	/Fo	Assign line 1 discharge temperature probe channel – see /F3	6	0	7	-	-
S	IO -> Aln	/Fob	Assign line 2 discharge temperature probe channel – see /F3	0	0	7	-	-
S	IO -> Aln	/FS	Assign condensing pressure probe channel – see /F3	5	0	7	-	-
S	IO -> Aln	/FT	Assign line 1 suction pressure probe channel – see /F3	4	0	7	-	-
S	IO -> Aln	/FTB	Assign line 2 suction pressure probe channel – see /F3	0	0	7	-	-
S	IO -> Aln	/LS	Condensing pressure probe lower limit	-1/ -14.5	-1/ -14.5	/US	barg/ psig	/FS ≠ 0
S	IO -> Aln	/LT	Suction pressure probe lower limit, line 1	-1/ -14.5	-1/ -14.5	/UT	barg/ psig	/FT ≠ 0
S	IO -> Aln	/LTB	Suction pressure probe lower limit, line 2	-1/ -14.5	-1/ -14.5	/UTB	barg/ psig	/FTB ≠ 0
M	IO -> Aln	/P1	Type of probe, group 1 (S1, S2, S3) 0= PT1000 1= NTC	1	0	1	-	-
M	IO -> Aln	/P2	Type of probe, group 2 (S4, S5) 0= PT1000 1= NTC 2= 0-5 V 3= 4-20 mA	3	0	3	-	-

User	Display	Code	Description	Def.	Min.	Max.	UOM	Visibility
M	IO -> Aln	/P3	Type of probe, group 3 (S6) 0= PT1000 1= NTC 2= 0-5 V 3= 4-20 mA 4= 0-10V 5= NTC HT 6= 0.5-4.5 V	5	0	6	-	-
M	IO -> Aln	/P4	Type of probe, group 4 (S7) 1= NTC	1	1	1	-	-
S	IO -> Aln	/US	Condensing pressure probe upper limit	34.5/ 500.3	/LS	200/ 2900 (*)	barg/ psig	-
S	IO -> Aln	/UT	Suction pressure probe upper limit, line 1	9.3/ 134.8	/LT	45/ 652.5	barg/ psig	-
S	IO -> Aln	/UTB	Suction pressure probe upper limit, line 2	9.3/ 134.8	/LTB	45/ 652.5	barg/ psig	-

Digital input

S	IO -> dIn	DiA	Assign immediate external alarm digital input (0= function disabled; 1= ID1, 2= ID2; ...; 6= ID6.)	0	0	6	-	-
S	IO -> dIn	DiA1	Assign compressor 1 digital input, line 1 - see DiA	1	0	6	-	-
S	IO -> dIn	DiA2	Assign compressor 2 digital input, line 1 - see DiA	2	0	6	-	-
S	IO -> dIn	DiA3	Assign compressor 3 digital input, line 1 - see DiA	0	0	6	-	-
S	IO -> dIn	DiA4	Assign compressor 4 digital input, line 1 - see DiA	0	0	6	-	-
S	IO -> dIn	DiAA	Assign compressor 1 digital input, line 2 - see DiA	0	0	6	-	-
S	IO -> dIn	DiAB	Assign compressor 2 digital input, line 2 - see DiA	0	0	6	-	-
S	IO -> dIn	DiB	Assign delayed external alarm digital input - see DiA	0	0	6	-	-
S	IO -> dIn	DiF	Assign remote On/Off digital input, line 1 - see DiA	0	0	6	-	-
S	IO -> dIn	DiFB	Assign remote On/Off digital input, line 2 - see DiA	0	0	6	-	-
S	IO -> dIn	DiLv	Assign liquid level digital input - see DiA	0	0	6	-	-
S	IO -> dIn	DiSC	Assign set point compensation digital input - see DiA	0	0	6	-	-
S	IO -> dIn	DiS	Assign generic alarm digital input - see DiA	0	0	6	-	-
S	IO -> dIn	DiT	Assign low pressure digital input, line 1 - see DiA	0	0	6	-	-
S	IO -> dIn	DiTB	Assign low pressure digital input, line 2 - see DiA	0	0	6	-	-
S	IO -> dIn	DivA	Assign fan 1 digital input - see DiA	3	0	6	-	-
S	IO -> dIn	DivB	Assign fan 2 digital input - see DiA	4	0	6	-	-
S	IO -> dIn	DivC	Assign fan 3 digital input - see DiA	0	0	6	-	-
S	IO -> dIn	DivD	Assign fan 4 digital input - see DiA	0	0	6	-	-
S	IO -> dIn	DiY	Assign high pressure digital input - see DiA	5	0	6	-	-
S	IO -> dIn	RiA	External alarm digital input logic (0 = reverse; 1 = direct)	1	0	1	-	diA ≠ 0
S	IO -> dIn	RiA1	Compressor 1 digital input logic, line 1 - see RiA	1	0	1	-	diA1 ≠ 0
S	IO -> dIn	RiA2	Compressor 2 digital input logic, line 1 - see RiA	1	0	1	-	diA2 ≠ 0
S	IO -> dIn	RiA3	Compressor 3 digital input logic, line 1 - see RiA	1	0	1	-	diA3 ≠ 0
S	IO -> dIn	RiA4	Compressor 4 digital input logic, line 1 - see RiA	1	0	1	-	diA4 ≠ 0
S	IO -> dIn	RiAA	Compressor 1 digital input logic, line 2 - see RiA	1	0	1	-	diAA ≠ 0
S	IO -> dIn	RiAB	Compressor 2 digital input logic, line 2 - see RiA	1	0	1	-	diAB ≠ 0
S	IO -> dIn	riB	Delayed external alarm digital input logic - see RiA	1	0	1	-	diF ≠ 0
S	IO -> dIn	RiF	Remote On/Off digital input logic, line 1 - see RiA	1	0	1	-	diF ≠ 0
S	IO -> dIn	RiFB	Remote On/Off digital input logic, line 2 - see RiA	1	0	1	-	diFB ≠ 0
S	IO -> dIn	RiLv	Liquid level digital input logic - see RiA	1	0	1	-	diLv ≠ 0
S	IO -> dIn	RiSC	Set point compensation digital input logic - see RiA	1	0	1	-	diSC ≠ 0
S	IO -> dIn	riS	Generic alarm digital input logic - see RiA	1	0	1	-	diF ≠ 0
S	IO -> dIn	RiT	Low pressure digital input logic, line 1 - see RiA	1	0	1	-	diT ≠ 0
S	IO -> dIn	RiTb	Low pressure digital input logic, line 2 - see RiA	1	0	1	-	diTB ≠ 0
S	IO -> dIn	RivA	Fan 1 digital input logic - see RiA	1	0	1	-	divA ≠ 0
S	IO -> dIn	RivB	Fan 2 digital input logic - see RiA	1	0	1	-	divB ≠ 0
S	IO -> dIn	RivC	Fan 3 digital input logic - see RiA	1	0	1	-	divC ≠ 0
S	IO -> dIn	RivD	Fan 4 digital input logic - see RiA	1	0	1	-	divD ≠ 0
S	IO -> dIn	RiY	High pressure digital input logic - see RiA	1	0	1	-	diY ≠ 0

Analogue outputs

S	IO -> AO	/AD	Assign analogue output for generic modulating function 0= function disabled; 1= analogue output 1 (Y1); 2= analogue output 2 (Y2).	0	0	2	-	-
S	IO -> AO	/AE	Assign analogue output for inverter fan - see /AD	0	0	2	-	-
S	IO -> AO	/Ai	Assign inverter compressor 1 analogue output, line 1 - see /AD	0	0	2	-	-
S	IO -> AO	/AiB	Assign inverter compressor 1 analogue output, line 2 - see /AD	0	0	2	-	-
S	IO -> AO	Ao1M	Maximum output value for Y1	10	Ao1n	10	-	-
S	IO -> AO	Ao1n	Minimum output value for Y1	0	0	Ao1M	-	-
S	IO -> AO	Ao2M	Maximum output value for Y2	10	Ao2n	10	-	-
S	IO -> AO	Ao2n	Minimum output value for Y2	0	0	Ao2M	-	-

Digital outputs

S	IO -> dO	DoA1	Assign compressor 1 digital output, line 1 (0 = function disabled; 1 = NO1, 2 = NO2; ...; 6 = NO6)	1	0	6	-	-
S	IO -> dO	DoA2	Assign compressor 2 digital output, line 1 - see DoA1	2	0	6	-	-
S	IO -> dO	DoA3	Assign compressor 3 digital output, line 1 - see DoA1	0	0	6	-	-
S	IO -> dO	DoA4	Assign compressor 4 digital output, line 1 - see DoA1	0	0	6	-	-
S	IO -> dO	DoAA	Assign compressor 1 digital output, line 2 - see DoA1	0	0	6	-	-
S	IO -> dO	DoAB	Assign compressor 2 digital output, line 2 - see DoA1	0	0	6	-	-
S	IO -> dO	DoB	Assign global alarm digital output - see DoA1	5	0	6	-	-
S	IO -> dO	DoCH	Assign crankcase heater digital output - see DoA1	0	0	6	-	-
S	IO -> dO	DoH	Assign serious alarm digital output - see DoA1	0	0	6	-	-
S	IO -> dO	DoL1	Assign compressor 1 unloader digital output 1, line 1 - see DoA1	0	-2	6	-	-
S	IO -> dO	DoL2	Assign compressor 1 unloader digital output 2, line 1 - see DoA1	0	-2	6	-	-

User	Display	Code	Description	Def.	Min.	Max.	UOM	Visibility
S	IO->dO	DoM1	Assign compressor 1 unloader digital output 1, line 2 - see DoA1	0	-2	6	-	-
S	IO->dO	DoS	Assign generic step function digital output - see DoA1	0	0	6	-	-
S	IO->dO	DoT	Assign fan 1 digital output - see DoA1	3	0	6	-	-
S	IO->dO	DoT2	Assign fan 2 digital output - see DoA1	4	0	6	-	-
S	IO->dO	DoT3	Assign fan 3 digital output - see DoA1	0	0	6	-	-
S	IO->dO	DoT4	Assign fan 4 digital output - see DoA1	0	0	6	-	-
S	IO->dO	RoA1	Compressor 1 digital output logic, line 1 (0 = reverse; 1 = direct)	0	0	1	-	DoA1≠0
S	IO->dO	RoA2	Compressor 2 digital output logic, line 1 - see RoA1	0	0	1	-	DoA2≠0
S	IO->dO	RoA3	Compressor 3 digital output logic, line 1 - see RoA1	0	0	1	-	DoA3≠0
S	IO->dO	RoA4	Compressor 4 digital output logic, line 1 - see RoA1	0	0	1	-	DoA4≠0
S	IO->dO	RoAA	Compressor 1 digital output logic, line 2 - see RoA1	0	0	1	-	DoAA≠0
S	IO->dO	RoAB	Compressor 2 digital output logic, line 2 - see RoA1	0	0	1	-	DoAB≠0
S	IO->dO	RoB	Global alarm digital output logic - see RoA1	0	0	1	-	DoB≠0
S	IO->dO	RoCH	Crankcase heater digital output logic - see RoA1	0	0	1	-	DoCH≠0
S	IO->dO	RoH	Serious alarm digital output logic - see RoA1	0	0	1	-	DoH≠0
S	IO->dO	RoL1	Compressor 1 unloader digital output 1 logic, line 1 - see RoA1	0	0	1	-	DoL1≠0
S	IO->dO	RoL2	Compressor 1 unloader digital output 2 logic, line 1 - see RoA1	0	0	1	-	DoL2≠0
S	IO->dO	RoM1	Compressor 1 unloader digital output 1 logic, line 2 - see RoA1	0	0	1	-	DoM1≠0
S	IO->dO	RoS	Generic step function digital output logic - see RoA1	0	0	1	-	DoS≠0
S	IO->dO	RoT	Fan 1 digital output logic - see RoA1	0	0	1	-	DoT≠0
S	IO->dO	RoT2	Fan 2 digital output logic - see RoA1	0	0	1	-	DoT2≠0
S	IO->dO	RoT3	Fan 3 digital output logic - see RoA1	0	0	1	-	DoT3≠0
S	IO->dO	RoT4	Fan 4 digital output logic - see RoA1	0	0	1	-	DoT4≠0

Tab. 6.d

6.5 Alarms

User	Display	Code	Description	Def.	Min.	Max.	UOM	Visibility
Prevention								
M	SAF-> Prv	cLdP	High discharge pressure prevention, OFF delay between compressors	30	0	999	s	-
S	SAF-> Prv	LshP	Safety threshold for superheat protection	6	LshA	20	K	-
S	-	LSP	Safety delay for superheat protection, line 1	5	0	60	s	-
S	-	LSPb	Safety delay for superheat protection, line 2	5	0	60	s	-
M	SAF-> Prv	Pvd	High discharge pressure prevention, evaluation time	5	0	999	min	-
M	SAF-> Prv	Pvt	High discharge temperature prevention, threshold	18/ 261	0	45/ 652.5	barg/ psig	-
M	SAF-> Prv	Pvt_T	High discharge temperature prevention, threshold expressed as a temperature	55/ 131	0/ 32	150/ 302	°C/°F	-
Alarms								
S	-	A11	Delay time for delayed external alarm	0	0	240	min	-
M	CL1->ALM	Atc	Type of compressor alarm reset: 0 = automatic; 1= manual.	0	0	1	-	-
M	FAN->ALM	AtF	Type of fan alarm reset - see Atc	0	0	1	-	nF > 0
M	SAF->ALM	AtH	Type of high pressure switch alarm reset: 0 = automatic; 1= manual; 2= semi-automatic.	0	0	2	-	-
M	SAF->ALM	AtL	Type of low pressure switch alarm reset, line 1 - see AtH	0	0	2	-	-
M	SAF->ALM	AtLb	Type of low pressure switch alarm reset, line 2 - see AtH	0	0	2	-	-
M	SAF->ALM	AtLn	Evaluation time for switching from semi-automatic to manual reset for low pressure alarms	60	0	999	min	-
M	SAF->ALM	AtS	Type of low superheat alarm reset, line 1 - see AtH	1	0	2	-	-
M	SAF->ALM	AtSb	Type of low superheat alarm reset, line 2 - see AtH	1	0	2	-	-
M	SAF->ALM	cAD	Compressor alarm delay time	0	0	999	s	-
S	SAF->ALM	FObd	Global alarm delay time	0	0	999	s	-
S	SAF->ALM	Fod	Fan alarm delay time	0	0	999	s	nF > 0
M	SAF->ALM	HPE	High pressure alarm from probe delay time	60	0	999	s	-
M	SAF->ALM	HPn	Number of activations for switching from automatic to manual reset for high pressure alarm from pressure switch	3	0	9	-	-
M	SAF->ALM	HPt	High pressure alarm from probe threshold	45.8/ 664.1	0	150/ 2175 (*)	barg/ psig	-
M	SAF->ALM	HPt_T	High pressure alarm from probe threshold, expressed as a temperature	85/ 185	0/ 32	150/ 2175 (*)	°C/°F	-
M	SAF->ALM	HSe	High suction pressure from probe alarm delay, line 1	60	0	999	s	-
M	SAF->ALM	HSeb	High suction pressure from probe alarm delay, line 2	60	0	999	s	-
M	SAF->ALM	HSt	High suction pressure from probe alarm threshold, line 1	9.3/ 134.8	0	20/ 290	barg/ psig	-
M	SAF->ALM	HSt_T	High suction pressure alarm from probe threshold, line 1, expressed as a temperature	25/ 77	-99.9/ -147.8	99.9/ 211.8	°C/°F	-
M	SAF->ALM	HStb	High suction pressure alarm from probe threshold, line 2	9.3/ 134.8	0	20/ 290	barg/ psig	-
M	SAF->ALM	HStb_T	High suction pressure alarm from probe threshold, line 2, expressed as a temperature	25/ 77	-99.9/ -147.8	99.9/ 211.8	°C/°F	-
S	SAF->ALM	Htt	High discharge temperature alarm threshold, line 1	110/ 230	0/ 32	200/ 392	°C/°F	-
S	SAF->ALM	Httb	High discharge temperature alarm threshold, line 2	110/ 230	0/ 32	200/ 392	°C/°F	-
M	SAF->ALM	LDe	Low discharge pressure alarm from probe delay	60	0	999	s	-

User	Display	Code	Description	Def.	Min.	Max.	UOM	Visibility
M	SAF -> ALM	LDt	Low discharge pressure alarm from probe threshold	0	0	150/ 2175(*)	barg/ psig	-
M	SAF -> ALM	LDt_T	Low discharge pressure alarm from probe threshold, expressed as a temperature	0/ 32	0/ 32	150/ 302	°C/°F	-
S	SAF -> ALM	Lhdb	Emergency delay for superheat protection, line 2	5	0	60	s	-
S	SAF -> ALM	LLd	Liquid level alarm delay	60	0	500	min	-
M	SAF -> ALM	LPE	Low suction pressure from probe alarm delay, line 1	60	0	999	s	-
M	SAF -> ALM	LPEb	Low suction pressure from probe alarm delay, line 2	60	0	999	s	-
M	SAF -> ALM	LPn	Number of activations for switching from automatic to manual reset for low pressure alarm from pressure switch	3	0	9	-	-
M	SAF -> ALM	LPt	Low suction pressure alarm from probe threshold, line 1 (-1= alarm disabled)	0	-1/ -14.5	150/ 2175(*)	barg/ psig	-
M	SAF -> ALM	LPt_T	Low suction pressure alarm from probe threshold, line 1, expressed as a temperature	0/ 32	-99/ -146	150/ 302	°C/°F	-
M	SAF -> ALM	LPtb	Low suction pressure alarm from probe threshold, line 2 (-1= alarm disabled)	0	-1/ -14.5	150/ 2175(*)	barg/ psig	-
M	SAF -> ALM	LPtb_T	Low suction pressure alarm from probe threshold, line 2, expressed as a temperature	0/ 32	-99/ -146	150/ 302	°C/°F	-
S	SAF -> ALM	LSd	Low suction temperature alarm delay, line 1	300	0	999	s	-
S	SAF -> ALM	LSdb	Low suction temperature alarm delay, line 2	300	0	999	s	-
S	SAF -> ALM	LshA	Emergency threshold for superheat protection	2	-20	LshP	K	-
S	SAF -> ALM	LshC	Emergency control (duty cycle) activation time in a fixed period of 10 minutes	4	0	10	min	-
S	SAF -> ALM	Lshd	Emergency delay for superheat protection, line 1	5	0	60	s	-
U	SAF -> ALM	rES	Reset alarms	0	0	1	-	-
S	SAF -> ALM	SHLn	Evaluation time for switching from semi-automatic to manual reset for low superheat alarms	60	0	999	min	-
S	SAF -> ALM	SHn	Number of activations for switching from automatic to manual reset for low superheat alarm	3	0	9	-	-
M	SAF -> ALM	HtA	High ambient temperature alarm threshold	50/122	LtA	99.9/ 211.8	°C/°F	-
M	SAF -> ALM	LtA	Low ambient temperature alarm threshold	-20/ -4	-99.9/ -147.8	HtA	°C/°F	-
M	SAF -> ALM	HtE	High outside temperature alarm threshold	50/122	LtE	99.9/ 211.8	°C/°F	-
M	SAF -> ALM	LtE	Low outside temperature alarm threshold	-20/ -4	-99.9/ -147.8	HtE	°C/°F	-
M	SAF -> ALM	P11	Low suction temperature alarm threshold, line 1	-5/ -23	-99.9/ -147.8	99.9/ 211.8	°C/°F	-
M	SAF -> ALM	P11B	Low suction temperature alarm threshold, line 2	-5/ -23	-99.9/ -147.8	99.9/ 211.8	°C/°F	-

Tab. 6.e

6.6 Generic functions

User	Display	Code	Description	Def.	Min.	Max.	UOM	Visibility
S	-	GFA_1	Generic alarm function, control probe 1 0= not configured; 1= suction pressure, line 1 (SSP); 2= suction pressure, line 2 (SSPB); 3= condensing pressure (SCP); 4= ambient temperature (SA); 5= outside temperature (SE); 6= discharge temperature, line 1 (SDT) 7= discharge temperature, line 2 (SDTb); 8= suction temperature, line 1 (TGS); 9= suction temperature, line 2 (TGSB); 10= generic temperature (SG)	0	0	10	-	-
S	-	GFA_2	Generic alarm function, control probe 2 - see GFA_1	0	0	10	-	-
S	-	GFA_AA	Generic alarm function, action taken 0= none; 1= stop control; 2= reduce capacity; 3= fans at maximum speed	0	0	3	-	-
S	-	GFA_AI- Type	Generic alarm function, alarm type (0= signal only; 1= serious alarm)	0	0	1	-	-
S	-	GFA_D	Generic alarm function, differential	0	0	99.9	-	-
S	-	GFA_De	Generic alarm function, delay	0	0	30000	s	-

User	Display	Code	Description	Def.	Min.	Max.	UOM	Visibility
S	-	GFA_E	Generic alarm function, enable 0= always; 1= unit On; 2= unit Off; 3= control On; 4= compressor On; 5= external alarm from digital input; 6= unit Off due to alarm; 7= high pressure alarm; 8= low pressure alarm, line 1; 9= low pressure alarm, line 2; 10= high pressure prevention active; 11= general alarm active; 12= generic warning active; 13= all compressors OFF	0	0	13	-	-
S	-	GFA_Hth	General alarm function, high threshold	0	-50	200	-	-
S	-	GFA_Lth	General alarm function, low threshold	0	-50	200	-	-
S	-	GFA_n	Generic alarm function, number of attempts before switching from semi-automatic to manual	0	0	99	-	-
S	-	GFA_P	Generic alarm function, evaluation period for switching from semi-automatic to manual	0	0	999	min	-
S	-	GFA_r	Generic alarm function, reset type (0 = automatic; 1 = semi-automatic; 2 = manual)	0	0	2	-	-
S	-	GFA_WA	Generic alarm function, action taken on warning 0 = none; 1 = stop control; 2 = reduce capacity; 3 = fans at maximum speed	0	0	3	-	-
S	-	GFA_WD	Generic alarm function, warning differential	0	0	99.9	-	-
S	-	GFA_WDe	Generic alarm function, warning delay	0	0	30000	s	-
S	-	GFA_We	Generic alarm function, enable warning (0 = disabled; 1 = enabled)	0	0	1	-	-
S	-	GFA_WHth	General alarm function, high warning threshold	0	-50	200	-	-
S	-	GFA_WLth	General alarm function, low warning threshold	0	-50	200	-	-
S	-	GFM_1	Generic modulating function, control probe 1- see GFA_1	0	0	10	-	-
S	-	GFM_2	Generic modulating function, control probe 2- see GFA_1	0	0	10	-	-
S	-	GFM_CD	Generic modulating function: cut-off differential	0	0	20	-	-
S	-	GFM_D	Generic modulating function, differential	0	0	99.9	-	-
S	-	GFM_E	Generic modulating function, enable - see GFA_E	0	0	12	-	-
S	-	GFM_F	Generic modulating function, control variable 0 = GFM_1 – GFM_2; 1 = minimum between GFM_1 and GFM_2; 2 = maximum between GFM_1 and GFM_2; 3 = average between GFM_1 and GFM_2.	0	0	3	-	-
S	-	GFM_H	Generic modulating function, hysteresis	0	0	20	-	-
S	-	GFM_Kp	Generic modulating function, proportional gain	0	0	100	-	-
S	-	GFM_Max	Generic modulating function, maximum output value	0	0	100	-	-
S	-	GFM_Min	Generic modulating function, minimum output value	0	0	100	-	-
S	-	GFM_S	Generic modulating function, set point	0	-50	200	-	-
S	-	GFM_T	Generic modulating function, control type (0 = direct, 1 = reverse)	0	0	1-	-	-
S	-	GFM_Td	Generic modulating function, derivative time	0	0	100	s	-
S	-	GFM_Ti	Generic modulating function, integral time	0	0	900	s	-
S	-	GFS_1	Generic stepped function, control probe 1- see GFA_1	0	0	10	-	-
S	-	GFS_2	Generic alarm function, control probe 2 - see GFA_1	0	0	10	-	-
S	-	GFS_D	Generic stepped function, differential	0	0	99.9	-	-
S	-	GFS_E	Generic stepped function, enable - see GFA_E	0	0	12	-	-
S	-	GFS_F	Generic stepped function, control variable – see GFM_F	0	0	3	-	-
S	-	GFS_S	Generic stepped function, set point	0	-50	200	-	-
S	-	GFS_T	Generic stepped function, control type – see GFM_T	0	0	1	-	-

Tab. 6.f

6.7 Time bands

User	Display	Code	Description	Def.	Min.	Max.	UOM	Visibility
U	-	EnS	Enabe scheduler (0= disabled; 1= enabled)	0	0	1	-	-
U	-	d__	Date/time setting from supervisor, day	1	1	31	-	-
U	-	h__	Date/time setting from supervisor, hours	0	0	23	h	-
U	-	M__	Date/time setting from supervisor, month	1	1	12	-	-
U	-	m__	Date/time setting from supervisor, minutes	0	0	59	min	-
U	-	y__	Date/time setting from supervisor, year	20	20	99	-	-
U	-	SEh	End time band, hours	7	0	23	h	-
U	-	SEM	End time band, minutes	30	0	59	min	-
U	-	SSh	Start time band, hours	17	0	23	h	-
U	-	SSM	Start time band, minutes	30	0	59	min	-

Tab. 6.g

6.8 BMS port

User	Display	Code	Description	Def.	Min.	Max.	UOM	Visibility
BMS settings								
M	StG -> BMS	H0	BMS serial address	1	1	247	-	-
S	StG -> BMS	H1	BMS parity and stop bits: BMS serial port configuration 0= 1 stop bit, no parity; 1= 2 stop bits, no parity; 2= 1 stop bit, even parity; 3= 2 stop bits, even parity; 4= 1 stop bit, odd parity; 5= 2 stop bits, odd parity	0	0	5	-	-
M	StG -> BMS	H2	BMS baud rate 0= 1200 1= 2400 2= 4800 3= 9600 4= 19200 5= 38400 6= 57600 7= 115200	4	0	8	bit/s	-

Tab. 6.h

7. ALARMS AND SIGNALS

7.1 Types of alarms

The controller manages three types of alarms, depending on the reset mode:

- **A - automatic:** the alarm is reset and the device restarts automatically when the alarm condition is no longer present;
- **R - semi-automatic:** if the alarm occurs several times, reset becomes manual and an operator needs to physically restart the device.
- **M - manual:** an operator needs to physically restart the device.

Alarms that require technical service are shown on the display with the flashing spanner icon. If the spanner icon is on, it means that a device has reached the programmed operating hour threshold, and maintenance is required (the alarm code indicates which device is affected).

For some alarms, the reset mode can be configured by parameter. The configurable alarms are:

- Compressor alarms (Atc);
- Fan alarms (AtF);
- High pressure switch (AtH)
- Low pressure switch - Line 1 (AtL)
- Low pressure switch - Line 2 (AtLb)
- Low superheat - Line 1 (AtS)
- Low superheat - Line 2 (AtSb)

User	Code	Description	Def	Min	Max	UOM
M	AtH	Type of high pressure switch alarm reset 0 = Automatic - 1 = Manual - 2 = Semi-Automatic	0	0	2	-
M	AtL	Type of low pressure switch alarm reset, line 1 – see AtH	0	0	2	-
M	AtLb	Type of low pressure switch alarm reset, line 2 – see AtH	0	0	2	-
M	Atc	Type of compressor alarm reset (0= automatic; 1= manual)	0	0	1	-
M	AtF	Type of fan alarm reset - see Atc	0	0	1	-
M	AtS	Type of low superheat alarm reset, line 1 – see AtH	1	0	2	-
M	AtSb	Type of low superheat alarm reset, line 2 – see AtH	1	0	2	-

Tab. 7.i

For each alarm with semi-automatic reset, the number of activations and/or the evaluation time before switching from automatic to manual can be set, using the corresponding parameters. See Tab. 7.c for details.

User	Code	Description	Def	Min	Max	UOM
M	AtLn	Evaluation time for switching from semi-automatic to manual reset for low pressure alarms	60	0	999	min
M	HPn	Number of activations for switching from automatic to manual reset for high pressure alarm from pressure switch	3	0	9	-
S	SHLn	Evaluation time for switching from semi-automatic to manual reset for low superheat alarms	60	0	999	min
S	SHn	Number of activations for switching from automatic to manual reset for low superheat alarm	3	0	9	-
M	Pvd	High discharge pressure prevention, evaluation time	5	0	999	min

Tab. 7.j

Alarms can also be distinguished according to priority:

- **Warning:** signal only, buzzer not activated;
- **Normal alarm:** signal only, buzzer activated;
- **Serious line alarm:** signal, buzzer activated and devices on the line in question switched off;
- **Serious unit alarm:** signal, buzzer activated and unit shut down.

7.2 Alarm signals

Alarms are signalled by buzzer and the flashing of the Alarm button. Pressing Alarm mutes the buzzer and displays the alarm code (on the top row) and any additional information (on the bottom row). Alarm activation is recorded in the alarm log. If the alarm is reset automatically, the Alarm button goes off, the alarm code is cleared from the list and the alarm reset event is recorded in the alarm log.

Alarms are also signalled by the activation of the global alarm and alarm notification digital outputs, if suitably configured using parameters DoB and DoH. Furthermore, the global alarm signal can be delayed by a time set using parameter FOdb.

User	Code	Description	Def	Min	Max	UOM
S	DoB	Assign global alarm digital output - see DoA1	5	0	6	-
S	DoH	Assign serious alarm digital output - see DoA1	0	0	6	-
S	FOdb	Global alarm delay time	0	0	999	s

Tab. 7.k

Alarm acknowledgement procedure



1. When an alarm is active, the buzzer sounds and the Alarm button lights up



2. Pressing Alarm mutes the buzzer and displays the alarm code; pressing UP/DOWN scrolls the list of any other alarms



3. When reaching the end of the alarm list, "ESC" is shown: press PRG to exit the alarm list.



4. Pressing the Alarm button for more than 3 s resets the alarms: "noAL" indicates that there are no more active alarms. Press PRG to exit the alarm list.

Pressing Alarm for more than 3 s while ESC is displayed resets all the alarms; a single alarm can be reset by pressing Alarm for more than 3 s while the corresponding code is displayed. If the condition that generated the alarm is still present, the alarm will be reactivated.

The alarms can also be reset from the 7-segment display, using parameter rES.

The same operations can be performed with APPLICA via smartphone, using the specific function on the alarm page (a BLE connection and "Service" level access are required).

Notice:

- deletion of the alarm log is irreversible;
- the buzzer is activated for all alarms.

7.3 Description of the main alarms

7.3.1 Digital input alarms

µRack manages two external alarms from digital input, IA and DA, which can be configured using parameters DiA and DiB. When these inputs are activated, a serious alarm is activated and the unit switches off, without waiting for the compressor times to elapse. Alarm DA can be delayed by a time set using parameter A11.

User	Code	Description	Def	Min	Max	UOM
S	A11	Delay time for delayed external alarm	0	0	240	min
S	DiA	Assign external alarm digital input: 0 = function disabled; 1= ID1, 2= ID2; ...; 6= ID6.	0	0	6	-
S	DiB	Assign delayed external alarm digital input - see DiA	0	0	6	-

Tab. 7.1

In addition to the generic digital input alarms, a specific alarm can be configured for each compressor and fan using parameters DiA1, ... DiAB and DivA... DivD. The alarms for the individual devices can be delayed using parameters cAD and Fod for the compressors and fans respectively.

User	Code	Description	Def	Min	Max	UOM
S	DiA1	Assign compressor 1 digital input, line 1 - see DiA	1	0	6	-
S	DiA2	Assign compressor 2 digital input, line 1 - see DiA	2	0	6	-
S	DiA3	Assign compressor 3 digital input, line 1 - see DiA	0	0	6	-
S	DiA4	Assign compressor 4 digital input, line 1 - see DiA	0	0	6	-
S	DiAA	Assign compressor 1 digital input, line 2 - see DiA	0	0	6	-
S	DiAB	Assign compressor 2 digital input, line 2 - see DiA	0	0	6	-
S	DivA	Assign fan 1 digital input - see DiA	3	0	6	-
S	DivB	Assign fan 2 digital input - see DiA	4	0	6	-
S	DivC	Assign fan 3 digital input - see DiA	0	0	6	-
S	DivD	Assign fan 4 digital input - see DiA	0	0	6	-
M	cAD	Compressor alarm delay time	0	0	999	s
S	Fod	Fan alarm delay time	0	0	999	s

Tab. 7.m

µRack also manages a liquid level alarm LQL from digital input, which can be configured using parameter DiLv. The alarm can be delayed by a time set using parameter LLd.

User	Code	Description	Def	Min	Max	UOM
S	ALM	Liquid level alarm delay	60	0	500	min
S	DiLv	Assign liquid level digital input - see DiA	0	0	6	-

Tab. 7.n

7.3.2 Pressure alarms and prevent

µRack can manage pressure alarms from a pressure switch or probe, according to the following scheme.

Alarms from pressure switch:

- Low suction pressure (LP1, LP2)
- High condensing pressure (HP1)

Alarms from probe:

- Low suction pressure (LP, LPb)
- High suction pressure (HS, HSb)
- Low condensing pressure (LPD)
- High condensing pressure (HP)

One possible example for the low pressure alarms is shown in the figure:

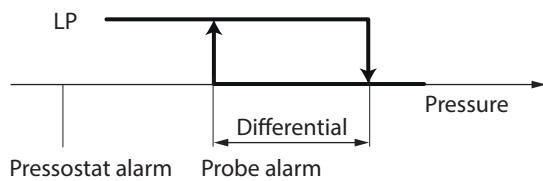

Fig. 7.aa

Furthermore, the high pressure alarms can be prevented by forcing the devices on. See “High pressure prevention”.

Alarms from pressure switch

The low suction pressure alarms from pressure switch LP1 and LP2 have the effect of stopping all the compressors on the line without observing the various times, therefore when the digital input configured as low pressure switch is activated, all the compressors on the line affected are stopped immediately. The type of reset can be selected using parameters AtL and AtLb. In the event of semi-automatic reset, both the evaluation time AtLn and the number of activations LPn in the specified period can be set. If the number of activations is higher than LPn, reset becomes manual.

The high condensing pressure alarm from pressure switch HP1 has the effect of shutting down the unit, without observing the compressor times. The type of reset can be selected using parameter AtH. In the event of semi-automatic reset, the number of activations HPn in the fixed 60 minute period can be set.. If the number of activations is higher than HPn, reset becomes manual.

User	Code	Description	Def	Min	Max	UOM
M	AtH	Type of high pressure switch alarm reset 0 = automatic; 1 = manual; 2 = semi-automatic	0	0	2	-
M	AtL	Type of low pressure switch alarm reset, line 1 – see AtH	0	0	2	-
M	AtLb	Type of low pressure switch alarm reset, line 2 – see AtH	0	0	2	-
M	AtLn	Evaluation time for switching from semi-automatic to manual reset for low pressure alarms	60	0	999	min
M	HPn	Number of activations for switching from automatic to manual reset for high pressure alarm from pressure switch	3	0	9	-
M	LPn	Number of activations for switching from automatic to manual reset for low pressure alarm from pressure switch	3	0	9	-

Tab. 7.0

Pressure alarms from probe

The probe pressure alarms all have automatic reset, and the activation threshold can be set for each alarm; the return differential is fixed at 1 bar/psi, as shown in the example in the figure. Moreover, for each alarm, a specific activation delay can be set. For control by temperature, the alarm thresholds taken into consideration are those set as temperature, converted to pressure. See the Alarm list for the effects of each probe pressure alarm.

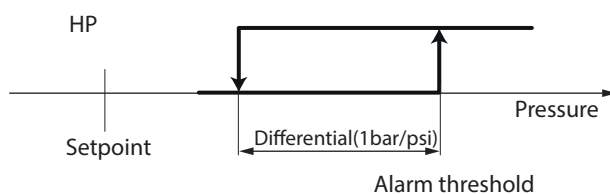

Fig. 7.ab

User	Code	Description	Def	Min	Max	UOM
M	HPE	High pressure alarm from probe delay time	60	0	999	s
M	HPt	High pressure alarm from probe threshold	45.8/ 664.1	0	150/ 2175 (*)	barg/ psig
M	HPt_T	High pressure alarm from probe threshold, expressed as a temperature	85/185	0/ 32	150/302	°C/°F
M	HSe	High suction pressure from probe alarm delay, line 1	60	0	999	s
M	HSeb	High suction pressure from probe alarm delay, line 2	60	0	999	s
M	HSt	High suction pressure alarm from probe threshold, line 1	9.3/ 134.8	0	20/ 290	barg/ psig
M	HSt_T	High suction pressure alarm from probe threshold, line 1, expressed as a temperature	25/77	-99.9/ -147.8	99.9/ 211.8	°C/°F
M	HStb	High suction pressure alarm from probe threshold, line 2	9.3/ 134.8	0	20/290	barg/ psig
M	HStb_T	High suction pressure alarm from probe threshold, line 2, expressed as a temperature	25/ 77	-99.9/ -147.8	99.9/ 211.8	°C/°F
M	LDe	Low discharge pressure alarm from probe delay	60	0	999	s
M	LDt	Low discharge pressure alarm from probe threshold	0	0	150/ 2175 (*)	barg/ psig
M	LDt_T	Low discharge pressure alarm from probe threshold, expressed as a temperature	0/ 32	0/ 32	150/ 302	°C/°F
M	LPE	Low suction pressure from probe alarm delay, line 1	60	0	999	s
M	LPEb	Low suction pressure from probe alarm delay, line 2	60	0	999	s
M	LPt	Low suction pressure alarm from probe threshold, line 1 (-1= alarm disabled)	0	-1/ -14.5	150/ 2175 (*)	barg/ psig
M	LPt_T	Low suction pressure alarm from probe threshold, line 1, expressed as a temperature	0/ 32	-99/ -146	150/ 302	°C/°F
M	LPtb	Low suction pressure alarm from probe threshold, line 2 (-1= alarm disabled)	0	-1/ -14.5	150/ 2175 (*)	barg/ psig
M	LPtb_T	Low suction pressure alarm from probe threshold, line 2, expressed as a temperature	0/ 32	-99/ -146	150/ 302	°C/°F
M	HtA	High ambient temperature alarm threshold	50/122	LtA	99.9/ 211.8	°C/°F
M	LtA	Low ambient temperature alarm threshold	-20/-4	-99.9/ -147.8	HtA	°C/°F
M	HtE	High outside temperature alarm threshold	50/122	LtE	99.9/ 211.8	°C/°F
M	LtE	Low outside temperature alarm threshold	-20/-4	-99.9/ -147.8	HtE	°C/°F
M	P11	Low suction temperature alarm threshold, line 1	-5/-23	-99.9/ -147.8	99.9/ 211.8	°C/°F
M	P11B	Low suction temperature alarm threshold, line 2	-5/-23	-99.9/ -147.8	99.9/ 211.8	°C/°F

Tab. 7.p

7.3.3 Temperature alarms

If the corresponding probes have been configured using the “/F” parameters μRack manages various probe temperature alarms:

- High discharge temperature, line 1 (HC)
- High discharge temperature, line 2 (HCb)
- Low suction temperature, line 1 (LSA)
- Low suction temperature, line 2 (LSB)
- High outside temperature (HiE)
- Low outside temperature (LiE)
- High ambient temperature (HiA)
- Low ambient temperature (LiA)

For the high discharge temperature alarms, the thresholds Htt and Httbv can be set, while for the other alarms the thresholds are fixed, as shown in the table.

Alarm	Threshold
LSA	-5 °C/ 23 °F
LSB	-5 °C/ 23 °F
HiE	50 °C/ 122 °F
LiE	-20 °C/ -4 °F
HiA	50 °C/ 122 °F
LiA	-20 °C/ -4 °F

Finally, for the low suction temperature alarms, the activation delays LSd and LSdb can be set.

7.3.4 Device maintenance request

µRack manages the maintenance requests on exceeding the operating hour threshold for devices AM1...AMB and FM1...FM4. The operating hour threshold for the compressors is the same for line 1 and line 2 (parameters HMP and HMPb) and for the fans (parameter FMP), while the counter is reset individually for each device, using parameters HMR1...HMRB and FMr1...FMr4.

If the thresholds HMP, HMPb and FMP are set to zero, the corresponding maintenance requests are disabled.

User	Code	Description	Def	Min	Max	UOM
S	HMP	Maintenance alarm threshold for line 1 compressors, expressed in hundreds of hours (0= alarm disabled)	0	0	999	hx100
S	HMPb	Maintenance alarm threshold for line 2 compressors, expressed in hundreds of hours (0= alarm disabled)	0	0	999	hx100
S	HMR1	Reset operating hours, compressor 1 line 1	0	0	1	-
S	HMR2	Reset operating hours, compressor 2 line 1	0	0	1	-
S	HMR3	Reset operating hours, compressor 3 line 1	0	0	1	-
S	HMR4	Reset operating hours, compressor 4 line 1	0	0	1	-
S	HMRa	Reset operating hours, compressor 1 line 2	0	0	1	-
S	HMRb	Reset operating hours, compressor 2 line 2	0	0	1	-
S	FMP	Maintenance alarm threshold for condenser fans, expressed in hundreds of hours (0= alarm disabled)	0	0	320	hx100
S	FMr1	Reset operating hours, fan 1	0	0	1	-
S	FMr2	Reset operating hours, fan 2	0	0	1	-
S	FMr3	Reset operating hours, fan 3	0	0	1	-
S	FMr4	Reset operating hours, fan 4	0	0	1	-

Tab. 7.q

7.4 Alarm list

Code	Description	Reset	Effect	Priority	Delay	No. of attempts	Period for eval. (s)	Troubleshooting
ETC	RTC fault	A	Disable the scheduler	Alarm	No	-	-	<ul style="list-style-type: none"> The date and time have been lost. Set them again If the error is repeated, the RTC battery may be discharged or the RTC chip damaged.
E1	Probe 1 fault alarm	A	(*)	Alarm	10s	-	-	<ul style="list-style-type: none"> Check the physical wiring of inputs S1 to S7 Check the input group type settings (/P1, /P2, /P3, /P4) Check the limits for active probes
E2	Probe 2 fault alarm	A	(*)	Alarm	10s	-	-	
E3	Probe 3 fault alarm	A	(*)	Alarm	10s	-	-	
E4	Probe 4 fault alarm	A	(*)	Alarm	10s	-	-	
E5	Probe 5 fault alarm	A	(*)	Alarm	10s	-	-	
E6	Probe 6 fault alarm	A	(*)	Alarm	10s	-	-	
E7	Probe 7 fault alarm	A	(*)	Alarm	10s	-	-	
IA	Immediate external alarm from DIN	A	Unit shutdown	Serious, unit	No	-	-	<ul style="list-style-type: none"> Check the connected external devices (e.g. HP or LP switches, common compressor alarms). Check the settings of "DIA" and "RIA".
AC1	Compressor 1 fault from DIN, line 1	Par. Atc	Switch off comp. 1 line 1	Line 1 alarm	Par. cAD	-	-	Check the status of compressors 1 to 4
AC2	Compressor 2 fault from DIN, line 1	Par. Atc	Switch off comp. 2 line 1	Line 1 alarm	Par. cAD	-	-	
AC3	Compressor 3 fault from DIN, line 1	Par. Atc	Switch off comp. 3 line 1	Line 1 alarm	Par. cAD	-	-	
AC4	Compressor 4 fault from DIN, line 1	Par. Atc	Switch off comp. 4 line 1	Line 1 alarm	Par. cAD	-	-	
ACA	Compressor 1 fault from DIN, line 2	Par. Atc	Switch off comp. 1 line 2	Line 2 alarm	Par. cAD	-	-	Check the status of compressors 1, 2 in line 2
ACb	Compressor 2 fault from DIN, line 2	Par. Atc	Switch off comp. 2 line 2	Line 2 alarm	Par. cAD	-	-	
AF1	Fan 1 fault	Par. AtF	Switch off fan 1	Alarm	Par. Fod	-	-	Check the conditions of the condenser fans
AF2	Fan 2 fault	Par. AtF	Switch off fan 2	Alarm	Par. Fod	-	-	
AF3	Fan 3 fault	Par. AtF	Switch off fan 3	Alarm	Par. Fod	-	-	
AF4	Fan 4 fault	Par. AtF	Switch off fan 4	Alarm	Par. Fod	-	-	
HPv	High condensing pressure prevention	A (R)	-	Alarm	No	5	Par. Pvd	<ul style="list-style-type: none"> Check that the fans are working correctly Check the settings of Pvt, Pvd, cLdP, Pvt_T Check that the condensing pressure probe is working

Code	Description	Reset	Effect	Priority	Delay	No. of attempts	Period for eval. (s)	Troubleshooting
HP	High condensing pressure alarm from probe	A	Unit shutdown	Serious, unit	Par. HPE	-	-	<ul style="list-style-type: none"> • Check the connection and reading of the discharge pressure probe • Check the condition of the condenser fan: there may be damage. • Check the condition of the condenser: it may be full of liquid after being inactive for a long time • Check the compressor discharge line: it may be blocked with dirt. • Check the oil separator: it may be mechanically blocked, preventing the refrigerant from flowing
LP	Low suction pressure alarm from probe, line 1	A	Shut down line 1	Serious, line 1	Par. LPE	-	-	<ul style="list-style-type: none"> • Check the connection and reading of the suction pressure probe on line 1 • Check the condition of the cabinets and cold rooms on line 1: the expansion valves may be closed. • Check the settings of the compressors on line 1, adjusting compressor control if the system is too slow in switching off the compressors.
LPb	Low suction pressure alarm from probe, line 2	A	Shut down line 2	Serious, line 2	Par. LPEb	-	-	<ul style="list-style-type: none"> • Check the connection and reading of the suction pressure probe on line 2 • Check the condition of the cabinets and cold rooms on line 2: the expansion valves may be closed. • Check the settings of the compressors on line 2, adjusting compressor control if the system is too slow in switching off the compressors.
HP1	High condensing pressure from pressure switch	Par. AtH	Unit shutdown	Serious, unit	No	Par. HPn	60 min	<ul style="list-style-type: none"> • Check the connection and condition of the high pressure switch • Check the condition of the condenser fan: there may be damage. • Check the condition of the condenser: it may be full of liquid after being inactive for a long time • Check the compressor discharge line: it may be clogged with dirt. • Check the oil separator: it may be mechanically blocked, preventing the refrigerant from flowing
LP1	Low suction pressure alarm from pressure switch, line 1	Par. AtL	Shut down line 1	Serious, line 1	No	Par. LPn	Par. AtLn	<ul style="list-style-type: none"> • Check the connection and condition of the low pressure switch on line 1 • Check the condition of the cabinets and cold rooms on line 1: the expansion valves may be closed. • Check the settings of the compressors on line 1, adjusting compressor control if the system is too slow in switching off the compressors.
LP2	Low suction pressure alarm from pressure switch, line 2	Par. AtLb	Shut down line 2	Serious, line 2	No	Par. LPn	Par. AtLn	<ul style="list-style-type: none"> • Check the connection and condition of the low pressure switch on line 2 • Check the condition of the cabinets and cold rooms on line 2: the expansion valves may be closed. • Check the settings of the compressors on line 2, adjusting compressor control if the system is too slow in switching off the compressors.
LDP	Low condensing pressure alarm from probe	A	-	Alarm	Par. LDe	-	-	<ul style="list-style-type: none"> • Check the position of the discharge pressure probe • Check for any leaks on the discharge piping • Check the fan activation settings • Check the low discharge pressure settings (threshold, delay)
HS	High suction pressure alarm from probe, line 1	A	-	Line 1 alarm	Par. HSe	-	-	<ul style="list-style-type: none"> • Check the position of the suction pressure probe • Check the condition of the expansion valves on the cabinet side • Check the compressor control and activation settings • Check the high suction pressure settings (threshold, delay)

Code	Description	Reset	Effect	Priority	Delay	No. of attempts	Period for eval. (s)	Troubleshooting
HSb	High suction pressure alarm from probe, line 2	A	-	Line 2 alarm	Par. HSeb	-	-	<ul style="list-style-type: none"> • Check the position of the suction pressure probe on line 2 • Check the condition of the expansion valves on the cabinet side, line 2 • Check the compressor control and activation settings on line 2 • Check the high suction pressure settings (threshold, delay) on line 2
HCS	High discharge temperature alarm, line 1	A	Shut down line 1	Serious, line 1	No	-	-	<ul style="list-style-type: none"> • Check for oil in suction line 1 • Check the setting of Htt
HCB	High discharge temperature alarm, line 2	A	Shut down line 2	Serious, line 2	No	-	-	<ul style="list-style-type: none"> • Check for oil in suction line 2 • Check the setting of Httb
LSH	Low superheat alarm, line 1	Par. AtS	Shut down line 1	Serious, line 1	Par. Lshd	Par. SHn	Par. SHLn	<ul style="list-style-type: none"> • Check the suction pressure and suction temperature readings in line 1 • Check the LSH settings (parameters P7, P8) • Check the operation of the expansion valves on the cabinets and in the cold rooms in line 1
LS2	Low superheat alarm, line 2	Par. AtSb	Shut down line 2	Serious, line 2	Par. Lhdb	Par. SHn	Par. SHLn	<ul style="list-style-type: none"> • Check the suction pressure and suction temperature readings in line 2 • Check the installation of the suction pressure and temperature probes in line 2 (position, transducer housing, ...) • Check the LSH settings (parameters P72, P82) • Check the operation of the expansion valves on the cabinets and in the cold rooms in line 2.
LSA	Low suction temperature alarm, line 1	A	-	Line 1 alarm	Par. LSd	-	-	<ul style="list-style-type: none"> • Check the reading of the suction temperature probe in line 1 • Check the installation of the suction temperature probe in line 1 (position, transducer housing, ...) • Check the LSA settings (P11, P12) • Check the operation of the expansion valves on the cabinets and in the cold rooms in line 1 • Check control of the cabinets and cold rooms (temperature stability) in line 1
LSB	Low suction temperature alarm, line 2	A	-	Line 2 alarm	Par. Lsdb	-	-	<ul style="list-style-type: none"> • Check the reading of the suction temperature probe in line 1 • Check the installation of the suction temperature probe in line 1 (position, transducer housing, ...) • Check the LSB settings (P31, P32) • Check the operation of the expansion valves on the cabinets and in the cold rooms in line 1 • Check control of the cabinets and cold rooms (temperature stability) in line 1
HiE	High outside temperature alarm	A	-	Alarm	No	-	-	<ul style="list-style-type: none"> • Check the outside temperature measurement • Check the connection of the outside temperature probe • Check the high outside temperature alarm settings
LiE	Low outside temperature alarm	A	-	Alarm	No	-	-	<ul style="list-style-type: none"> • Check the outside temperature measurement • Check the connection of the outside temperature probe • Check the high outside temperature alarm settings
HiA	High ambient temperature alarm	A	-	Alarm	No	-	-	<ul style="list-style-type: none"> • Check the ambient temperature measurement • Check the connection of the ambient temperature probe • Check the high ambient temperature alarm settings
LiA	Low ambient temperature alarm	A	-	Alarm	No	-	-	<ul style="list-style-type: none"> • Check the ambient temperature measurement • Check the connection of the ambient temperature probe • Check the high ambient temperature alarm settings
LQL	Liquid level alarm	A	-	Alarm	Par. LLd	-	-	<ul style="list-style-type: none"> • Check the refrigerant charge • Check the position of the liquid level sensor

Code	Description	Reset	Effect	Priority	Delay	No. of attempts	Period for eval. (s)	Troubleshooting
AM1	Compressor 1 maintenance request, line 1	M	-	Line 1 alarm	No	-	-	
AM2	Compressor 2 maintenance request, line 1	M	-	Line 1 alarm	No	-	-	<ul style="list-style-type: none"> • Check the compressor operating hours • Check the compressor maintenance threshold
AM3	Compressor 3 maintenance request, line 1	M	-	Line 1 alarm	No	-	-	
AM4	Compressor 4 maintenance request, line 1	M	-	Line 1 alarm	No	-	-	
AMA	Compressor 1 maintenance request, line 2	M	-	Line 2 alarm	No	-	-	
AMb	Compressor 2 maintenance request, line 2	M	-	Line 2 alarm	No	-	-	<ul style="list-style-type: none"> • Check the compressor operating hours in line 2 • Check the compressor maintenance threshold in line 2
FM1	Fan 1 maintenance request	M	-	Alarm	No	-	-	<ul style="list-style-type: none"> • Check the fan operating hours • Check the fan maintenance threshold
FM2	Fan 2 maintenance request	M	-	Alarm	No	-	-	
FM3	Fan 3 maintenance request	M	-	Alarm	No	-	-	
FM4	Fan 4 maintenance request	M	-	Alarm	No	-	-	
dA	External DIN alarm delay	A	Stop control	Serious alarm	Par. A11	-	-	<ul style="list-style-type: none"> • Check the connected external devices • Check the settings of "Dib" and "rlb"
GHI	Generic alarm 1 - High	Par. GFA_r	see par. GFA_AA	Par. GFA_AIType	Par. GFA_De	Par. GFA_n	Par. GFA_P	<ul style="list-style-type: none"> • Check the probe associated with the generic alarm function (GFA_1 and GFA_2) • Check the threshold (GFA_Hth)
GLO	Generic alarm 1 - Low	Par. GFA_r	see par. GFA_AA	Par. GFA_AIType	Par. GFA_De	Par. GFA_n	Par. GFA_P	<ul style="list-style-type: none"> • Check the probe associated with the generic alarm function (GFA_1 and GFA_2) • Check the threshold (GFA_Lth)
CfU	Analogue input configuration error	A	-	Alarm	0s	-	-	Check if there are multiple analogue inputs configured on the same channel
CfD	Digital input configuration error	A	-	Alarm	0s	-	-	Check if there are multiple digital inputs configured on the same channel
CfA	Analogue output configuration error	A	-	Alarm	0s	-	-	Check if there are multiple analogue outputs configured on the same channel
CfO	Digital output configuration error	A	-	Alarm	0s	-	-	Check if there are multiple digital outputs configured on the same channel
uGH	Generic alarm 1 - High	A	see par. GFA_WA	Alarm	Par. GFA_WDe	-	-	<ul style="list-style-type: none"> • Check the probe associated with the generic alarm function (GFA_1 and GFA_2) • Check the threshold (GFA_WHth)
uGL	Generic alarm 1 - Low	A	see par. GFA_WA	Alarm	Par. GFA_WDe	-	-	<ul style="list-style-type: none"> • Check the probe associated with the generic alarm function (GFA_1 and GFA_2) • Check the threshold (GFA_WLth)

Tab. 7.r

(*) : The alarm refers to the physical channel on the controller. The effect of the probe alarm will differ depending on the type of input selected.

8. TECHNICAL SPECIFICATIONS

Model	U20R00MRK0280 (panel models)	U20R00MRK0290 and U20R00MRK0300 (DIN models)
Physical specifications		
Dimensions	See figures (par. 2.2.1)	See figures (par. 2.3.1)
Case	Polycarbonate	Polycarbonate
Mounting	panel	DIN rail
Ball pressure test temperature	125°C	125°C
Ingress protection	IP20 (rear) - IP65 (front)	IP00
Front cleaning	Use a soft non-abrasive cloth, neutral detergents or water	-
Environmental conditions		
Storage conditions	-40T80°C, <90 % RH non-condensing	-40T80°C, <90 % RH non-condensing
Operating conditions	-20T60°C, <90 % RH non-condensing	-20T60°C, <90 % RH non-condensing
Electrical specifications		
Rated power supply	24 Vac/dc (SELV or PELV power supply, Class 2)	24 Vac/dc (SELV or PELV power supply, Class 2)
Operating power supply voltage	24 Vac/dc, +10% -15%	24 Vac/dc, +10% -15%
Input frequency (AC)	50/60 Hz	50/60 Hz
Maximum current draw	600 mA rms	DIN without ExV valve driver: 600 mArms DIN with ExV valve driver: 1.25 Arms
Power for transformer sizing	15 VA	Models without valve driver: 15 VA Models with valve driver: 30 VA
Clock	precision: ± 50 ppm; min time maintenance after power off: 6 months	precision: ± 50 ppm; min time maintenance after power off: 6 months
Software class and structure	A	A
Pollution degree	3	3
Class of protection against electric shock	To be incorporated in class I or II appliances	To be incorporated in class I or II appliances
Type of action and disconnection	1.C	1.C
Rated impulse voltage	relay outputs: 4 kV; 24 V input: 0.5 kV	relay outputs: 4 kV; 24 V input: 0.5 kV
Surge immunity category	relay outputs: III; 24 V input: II	relay outputs: III; 24 V input: II
Control device construction	Device to be incorporated	Device to be incorporated
Terminal block	Plug-in male-female. Wire sizes: see the connector table	Plug-in male-female. Wire sizes: see the connector table
Purpose of the controller	Electrical operating control	Electrical operating control
User interface		
Buzzer	built-in	not included on the controller, fitted on the remote HMI interface
Display	LED 2 rows, decimal point and multifunctional icons	LED 2 rows, decimal point, and multi-function icons
Connectivity		
NFC	Max distance 10 mm, variable according to the mobile device used	Max distance 10 mm, variable according to the mobile device used
Bluetooth Low Energy	Max distance 10m, variable according to the mobile device used	Max distance 10m, variable according to the mobile device used
BMS serial interface	Modbus® over RS485, not opto-isolated	Modbus® over RS485, not opto-isolated
FieldBUS serial interface.	Modbus® over RS485, not opto-isolated	Modbus® over RS485, not opto-isolated
HMI interface	Modbus® over RS485, not opto-isolated	Modbus® over RS485, not opto-isolated
Analogue inputs (Lmax=10m)		
J2 S1, S2, S3: NTC S5: 0 to 5 V ratiometric / 4-20 mA / NTC	NTC: resolution 0.1 °C; 10Kohm@25°C, error: ± 1°C in the range - 50T50°C, ± 3°C in the range 50T90°C;	NTC: resolution 0.1 °C; 10Kohm@25°C, error: ± 1°C in the range - 50T50°C, ± 3°C in the range 50T90°C;
J3 S4: 0 to 5 V ratiometric / 4-20 mA / NTC S6: 0 to 5 V ratiometric / 0-10V / 4-20mA / NTC	0-5 V ratiometric: error 2% fs, typical 1%; 4-20mA: error 5% fs, typical 1% 0-10 V: error 2% fs, typical 1%	0-5 V ratiometric: error 2% fs, typical 1%; 4-20mA: error 5% fs, typical 1% 0-10 V: error 2% fs, typical 1%
J9 S7: NTC (DIN version only)	-	NTC: resolution 0.1 °C; 10Kohm@25°C, error: ± 1°C in the range - 50T50°C ± 3°C in the range 50T90 ° C
Digital inputs (Lmax=10m)		
Model	U20R00MRK0280 (panel models)	U20R00MRK0290 and U20R00MRK0300 (DIN models)
J2 ID1(*)	Voltage-free contact, not optically-isolated, typical closing current 6 mA, voltage with contact open 13 V, max contact resistance 50 Ω.	Voltage-free contact, not optically-isolated, typical closing current 6 mA, voltage with contact open 13 V, max contact resistance 50 Ω.
J2 ID2	-	-
J3 ID3(*), ID4, ID5	-	-
J9 ID6 - available only on DIN	-	-
(*) Fast digital input: 0-2 kHz; error 2% fs		
Valve output		
J14	Available only on DIN version	CAREL E*V unipolar valve power supply: 13 Vdc, min winding resistance 40 Ω
Analogue outputs (Lmax=10m)		
J2	Y1, Y2	0 to 10 Vdc: 10 mA max

Model	U20R00MRK0280 (panel models)	U20R00MRK0290 and U20R00MRK0300 (DIN models)
Digital outputs (Lmax=10m)		
<p>Notice: the sum of current draw on NO1, NO2, NO3 and NO4 must not exceed 8 A</p>		
J6	NO1, NO2, NO3, NO4	5A: EN60730: 5A resistive, 250Vac, 50k cycles;
J7	NO5	4(1), 230Vac, 100k cycles; 3(1), 230Vac, 100k cycles
J11	NO6 available only on DIN version	UL60730: 5A resistive, 250Vac, 30k cycles; 1FLA, 6LRA, 250Vac, 30k cycles; Pilot Duty C300, 30k cycles SSR: solid state relay, 0,4A 100-240Vac 50/60Hz
Emergency power supply		
J10:	Ultracap module (optional, available only on DIN version)	- 13 Vdc ±10%
Probe and terminal power supply (Lmax=10m)		
5V	5 Vdc ± 2% to power the 0 to 5 V ratiometric probes. Max current delivered: 35 mA protected against short-circuits	5 Vdc ± 2% to power the 0 to 5 V ratiometric probes. Max current delivered: 35 mA protected against short-circuits
+V	8-11 V to power the 4-20 mA current probes. Maximum current delivered: 80 mA protected against short-circuits	8-11 V to power the 4-20 mA current probes. Maximum current delivered: 80 mA protected against short-circuits
VL	Not used	Not used
J8	User terminal power supply	User terminal power supply
Serial ports		
BMS	<ul style="list-style-type: none"> Lmax = 500 m, shielded cable (RS485 1½ twisted pair) (1) Integrated Protocol: Modbus® HW driver: asynchronous half duplex RS 485 Not optically-isolated 3-pin plug-in connector, 3.81 mm pitch Max data rate: 115200 bits/s Maximum number of connectable devices: 16 	<ul style="list-style-type: none"> Lmax = 500 m, shielded cable (RS485 1½ twisted pair) (1) Integrated Protocol: Modbus® HW driver: asynchronous half duplex RS 485 Not optically-isolated 3-pin plug-in connector, 3.81 mm pitch Max data rate: 115200 bits/s Maximum number of connectable devices: 16
FieldBus	<ul style="list-style-type: none"> Lmax = 10 m, shielded cable (RS485 1½ twisted pair) (1) Integrated HW driver: asynchronous half duplex RS 485. Typical reception resistance 96 kohms, equal to 1/8 of unit load, i.e. 1/256 of maximum load applicable on the line Not optically-isolated Max data rate: 19200 bits/s Maximum number of connectable devices: 16 Protocol: Modbus® RTU 	<ul style="list-style-type: none"> Lmax = 10 m, shielded cable (RS485 1½ twisted pair) (1) Integrated HW driver: asynchronous half duplex RS485. Typical reception resistance 96 kohms, equal to 1/8 of unit load, i.e. 1/256 of maximum load applicable on the line Not optically-isolated Max data rate: 19200 bits/s Maximum number of connectable devices: 16 Protocol: Modbus® RTU
Cable lengths		
Analogue inputs/outputs, digital inputs/ outputs, probe power	<10m	<10m
Valve	< 2 m, < 9m with shielded cable	< 2 m, < 9m with shielded cable
BMS and Fieldbus serial cables	<500m with shielded cable	<500m with shielded cable
Conformity		
Electrical safety	UL/IEC	EN/UL 60730-1, EN/UL 60335-1
Electromagnetic compatibility	CE	EN 61000-6-1, EN 61000-6-2, EN 61000-6-3, EN 61000-6-4
	Red	EN301489-1/EN301489-17, EN300328
	FCC	Contains FCC ID: WAP2001
Radio	IC	Contains ICs: 7922A-2001
	ANATEL	ID: 03780-21-05684 Este equipamento não tem direito à proteção contra interferência prejudicial e não pode causar interferência em sistemas devidamente autorizados
Applications with flammable refrigerant gases (*)	<p>The use of this product (except for SSR versions) with type A3, A2 or A2L flammable refrigerants, has been evaluated and found to comply with the following requirements:</p> <ul style="list-style-type: none"> Annex CC of IEC 60335-2-24:2010, referred to in clause 22.109, and annex BB of IEC 60335-2-89:2019 referred to in clause 22.113; components that produce arcs or sparks during normal operation have been tested and found to comply with the requirements of UL/IEC 60079-15; IEC 60335-2-24:2010 (clause 22.110) IEC 60335-2-40:2018 (clauses 22.116, 22.117) IEC 60335-2-89:2019 (clause 22.114) <p>The surface temperatures of all the components have been measured and verified during the tests required by IEC 60335 cl. 11 and 19 and found to be no higher than 268 °C.</p> <p>The versions with SSR comply with IEC 60335-2-40:2018 when using A2L refrigerants (e.g. R32); in particular, electronic components that may ignite a flame under normal operating conditions comply with clause JJ, and the maximum surface temperature of all components does not exceed 268°C, under normal operating conditions.</p> <p>The acceptability of these controllers in the final applications where flammable refrigerants are expected to be used must be reviewed and evaluated in the final application.</p>	

Tab. 8.a

Notice: (1) it is recommended to use a BELDEN 8761 cable (AWG 22).

8.1 Connector/cable table

Ref.	Description	Wiring terminals	Wire cross-section (mm ²)	Lmax (m)
J1	Controller power supply	Panel model: removable terminal, screw, 2-pin, pitch 5.08	0.5-1.5	10
		DIN rail model: removable terminal, screw, 2-pin, pitch 5.08	0.21-3.31	10
J2	Inputs S1, S2, S3, S5, ID1, ID2; outputs Y1, Y2	10-pin Microfit crimp connector	0.05-0.52	10
J3	Inputs S4, S6, ID3, ID4, ID5	8-pin Microfit crimp connector	0.05-0.52	10
J4	BMS	Plug-in screw terminal, 3-pin, pitch 3.81	0.081-1.31	500
J5	Fbus	Plug-in screw terminal, 3-pin, pitch 3.81	0.081-1.31	10
J6	Outputs NO1, NO2, NO3, NO4	6-pin Microfit crimp connector	0.5-1.31	10
J7	Output NO5	3-pin Microfit crimp connector	0.5-1.31	10
J8	Unit terminal	Connection cable part number: ACS00CB000010 (L=3m) /20 (L=1.5m)	00:13	2 (*)
J9	Inputs S7, ID6	4-pin Microfit crimp connector	0.05-0.52	10
J10	Ultracap	3-pin JST connector	00:13	2
J11	Output NO6	3-pin Microfit crimp connector	0.5-1.31	10
J14	Unipolar ExV valve	CAREL ExV unipolar valve connector, pre-wired	-	2, 6 with shielded cable

Tab. 8.b

(*) device to be incorporated.

9. RELEASE NOTES

Software version - date	Manual version - date	Release
1.0.0; 30/09/2021	1.0; 31/08/2021	First
2.10; 25/01/2023	2.0; 30/01/2023	Second (complete revision)

CAREL

CAREL INDUSTRIES - Headquarters

Via dell'Industria, 11 - 35020 Brugine - Padova (Italy)

Tel. (+39) 049.9716611 - Fax (+39) 049.9716600

e-mail: carel@carel.com - www.carel.com

μRack +0300026EN rel. 2.0 - 30.01.2023